



DERO 3V RACK

- *Elegant, Three dimensional Design*
- *Meets APBP recommended guidelines*
- *2-3 bike capacity in a small footprint*

The modern Dero 3V Rack takes a distinctive approach to bike parking. Like any quality bike rack, it fully supports the bike frame in two places and is U-lock compatible. The Dero 3V Rack's compact and efficient, three-dimensional footprint occupies minimal space, while providing parking for up to three bikes. Choose the Dero 3V to distinguish your building or project with unique, quality bicycle parking.



www.dero.com

1.800.298.4915



Printed on recycled paper

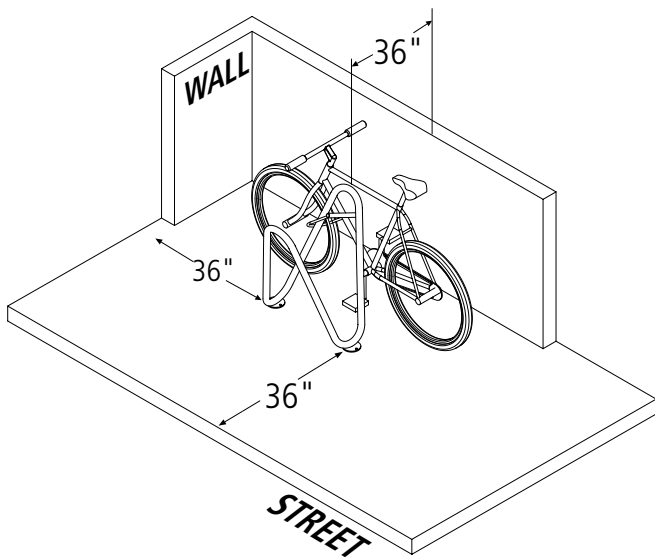
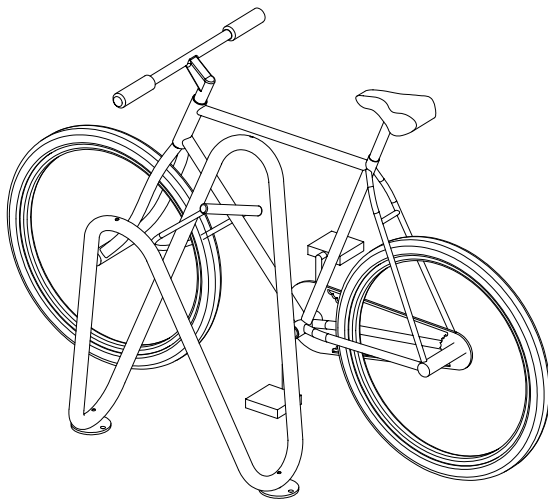
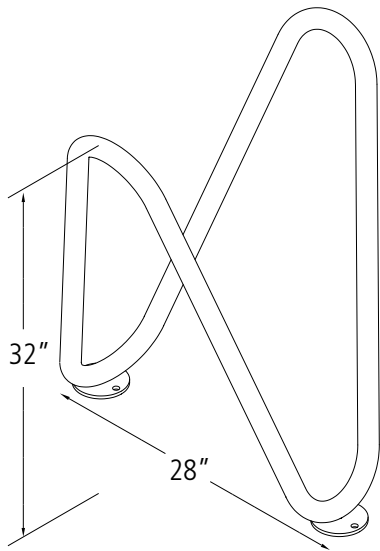

Product

Dero 3V Rack
As manufactured by Dero Bike Racks

Capacity

2-3 Bikes

Materials



1.5" tube 11 gauge

Finishes



An after fabrication hot dipped galvanized finish is standard. 250 TGIC powder coat colors, a thermoplastic coating and a stainless steel option are also available.

Our powder coat finish assures a high level of adhesion and durability by following these steps:

1. Sandblast
2. Iron phosphate pretreatment
3. Epoxy primer electrostatically applied
4. Final thick TGIC polyester powder coat

Stainless Steel: 304 grade stainless steel material finished in either a high polished shine or a satin finish.

Installation Methods



Foot Mount has two 4" diameter x .25" feet with two anchors per foot.

Space Use and Setbacks



Wall Setbacks:

For racks set parallel to a wall:
Minimum: 24"
Recommended: 36"

For racks set perpendicular to a wall:

Minimum: 28"
Recommended: 36"

Distance Between Racks:

Minimum: 24"
Recommended: 36"

Street Setbacks:

Minimum: 24"
Recommended: 36"

Tools Needed for Installation

- Tape Measure
- Marker or Pencil
- Masonry Drill Bit
- Drill (Hammer drill recommended)
- Hammer
- Wrench 9/16"
- Level

Recommended Base Materials:

Solid concrete is the best base material for installation. To ensure the proper anchors are shipped with your rack, ask your Dero Rack representative which anchor is appropriate for your application. Be sure nothing is underneath the base material that could be damaged by drilling.

Installation:

3/8" anchors are shipped with the rack. Place the rack in the desired location. Use a marker or pencil to outline the holes of the flange onto the base material. Drill the holes in accordance with the specifications shipped with the anchors. Make sure the holes are at least 3" away from any cracks in the base material. Use washers to level rack if necessary. Tap in anchors and follow your specific anchor instructions provided with the rack.

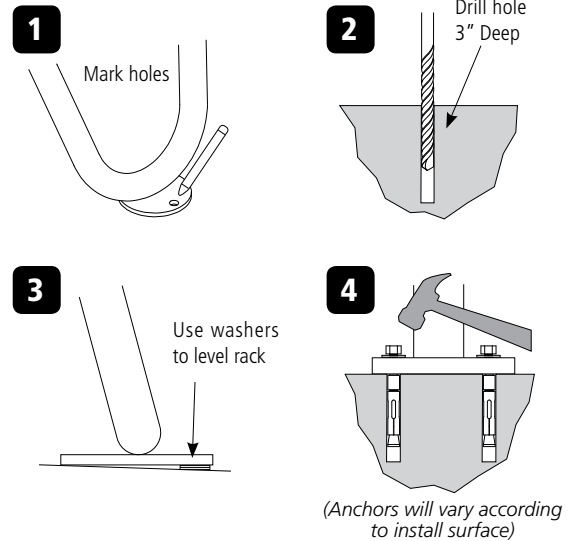
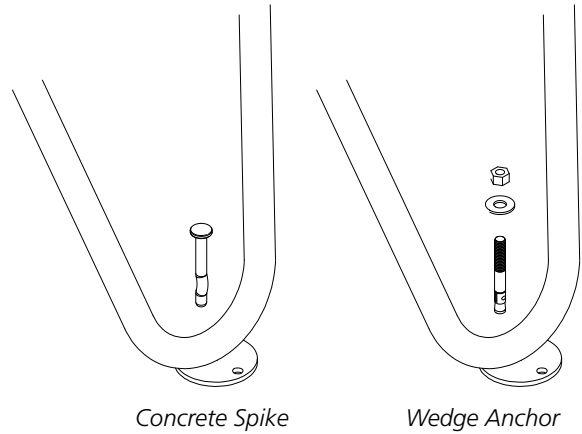

Tamper Resistant Fasteners

The concrete spike is a permanent anchor. The top of the wedge anchor can also be pounded sideways after installation so that it cannot be removed. Other tamper resistant fasteners are also available for purchase.

When using the special tamper resistant nuts, always set and first tighten the anchors. Once the rack is installed, replace two nuts from the bracket (opposite sides from each other) with the tamper resistant fastener. DO NOT OVERTIGHTEN the tamper resistant nut.

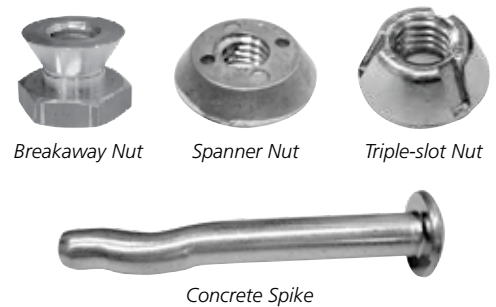

If you have any questions about installation or other features of the 3V Rack, please call us toll free at 1-800-298-4915

Tools Needed for Installation

- | | |
|-------------------|---------------------------------|
| Level | Hole coring machine with 4" bit |
| Cement mixing tub | Access to water hose |
| Shovel | |
| Trowel | |

Installing into Existing Sidewalk

Core holes no less than 3" diameter (4" recommended) and no less than 6" deep into sidewalk. Fill holes with Por-Rok or epoxy grout. Place 3V Rack into holes, making sure the rack is level. 33"-36" of the 3V Rack should remain above the surface. If the 3V Rack is less than 33" high, it will not support the bike adequately. Make sure the rack is level and held in place until the grout has set.

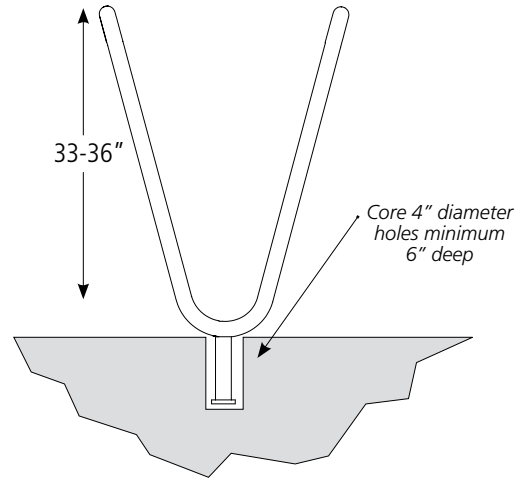

Installing Into a New Sidewalk:

Stake Method:

- 1 Use rack to measure exact location in pour bed.

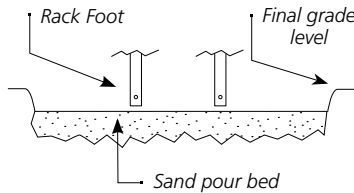

- 2 Pound stake into pour bed where end of rack will sit. Slide rack end onto stake. You may need to dig the end of the rack into the sand to make sure the rack sits at least 35" above final grade level. The stake keeps the rack straight while the concrete is being poured.

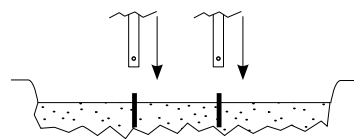

- 3 Make sure the rack is level and true. Pour concrete around the rack. Make sure the rack is not touched until the concrete has completely set.

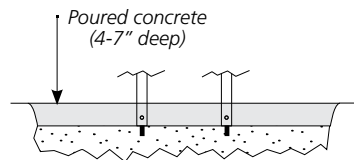

Sleeve Method:

- 1 Place corrosion resistant sleeve (min. 4" inside diameter) in sand pour bed in exact location where rack will be installed. Make sure top of sleeve is at same level as desired finished concrete surface. Fill sleeve with sand to keep it in place and prevent it from filling with concrete.

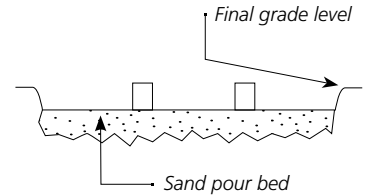

- 2 Pour concrete and allow to cure.

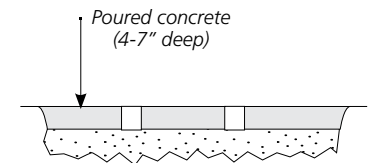

- 3 After appropriate cure time, dig out sand from sleeves and insert racks, making sure they are level and at the appropriate height. Pour in Por-Rok or epoxy grout and allow to set.

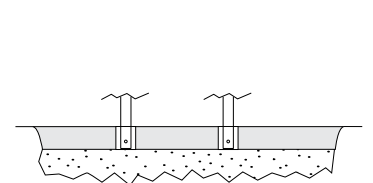

Note: Sleeve should have profile to keep it from coming loose from hardened concrete.

