



DERO POCKET SHELTER

- *Optional Benches*
- *Optional side and back panels*
- *Modular Construction - easy to add on*

Small and versatile, the Dero Pocket Shelter stores bikes in areas that would not normally accommodate bike parking. This shelter is a modular system that provides covered and secure bike storage but is extremely space efficient and cost-effective. The vertical Dero Ultra Space Saver system allows both the frame and wheel of each bike to be secured with a u-lock for the greatest bike security.

Optional side and back panels add increased protection against the elements. Optional interior or exterior benches are also available.

Covered bike parking earns your site LEED credits.



Rev C

 www.dero.com  1.800.337.6729



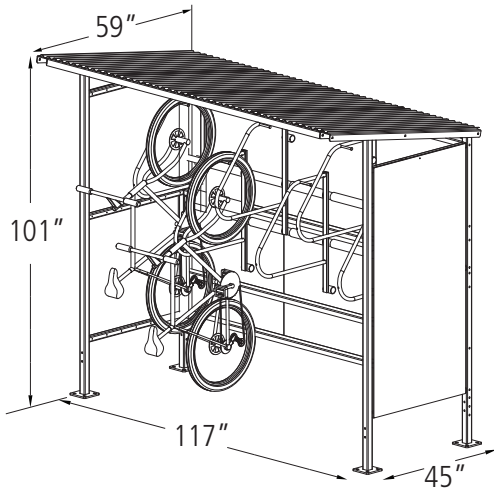

 Printed on recycled paper



Product Dero Pocket Shelter
As manufactured by Dero Bike Racks

Capacity With Ultra Space Savers: 6 Bikes
With Bike Files: 10 Bikes

Materials
 Uprights: 2" x 3/16" square tube
 Feet: 3/8" plate
Horizontal members: 3/16" formed sheet
Roof panels: 26g type S deck or 1/4" polycarbonate
Roof members: 3/16" formed sheet
Side panels: 1/4" polycarbonate

Finishes
 An after fabrication hot dipped galvanized finish is our standard option. 250 TGIC powder coat colors and a thermoplastic coating are also available as alternate options.

Our powder coat finish assures a high level of adhesion and durability by following these steps:

1. Sandblast
2. Epoxy primer electrostatically applied
3. Final thick TGIC polyester powder coat

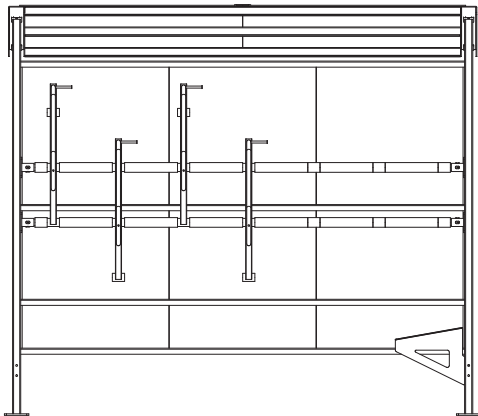

A bench may be mounted to the inside of the Pocket Shelter and still allow room for four bikes.

Installation Methods



Surface Mount has four 6" square feet which must be anchored to the ground with supplied anchors. See footing details on page 4.

Space Use and Setbacks



Consult local building codes for acceptable setbacks and placement.

Load Data



Dead load = self weight of structure
Live load = snow load = 45 psf
Wind load = 90 mph exposure B
Seismic load = moderate
Footing: see page 4
Anchor bolt = Simpson strong-bolt 2, 1/2" x 5 1/2", 3 7/8" minimum embed

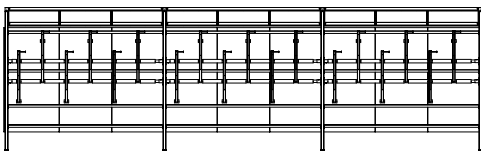

Dero Shelters can be used in a modular fashion (shared uprights). However, when used in this manner, please consult a Dero Bike Rack sales associate for layout, as the rack spacing and bike capacity can change!

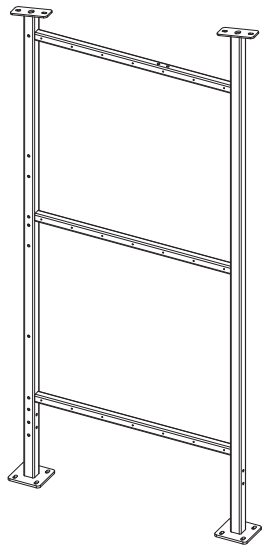

Upright

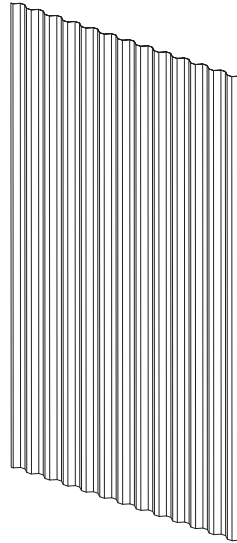

Type S Deck

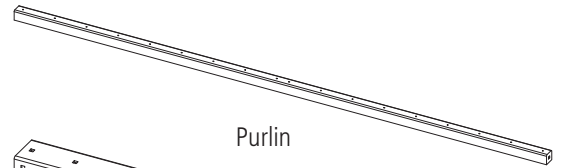

Purlin

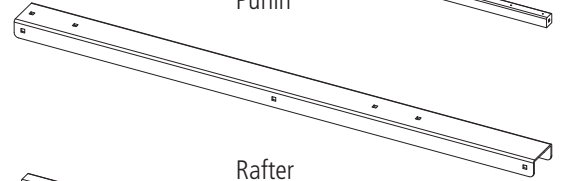

Rafter

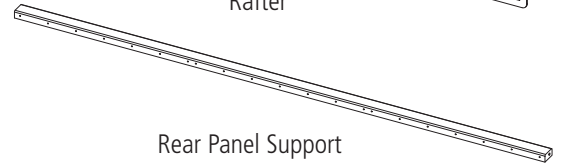

Rear Panel Support

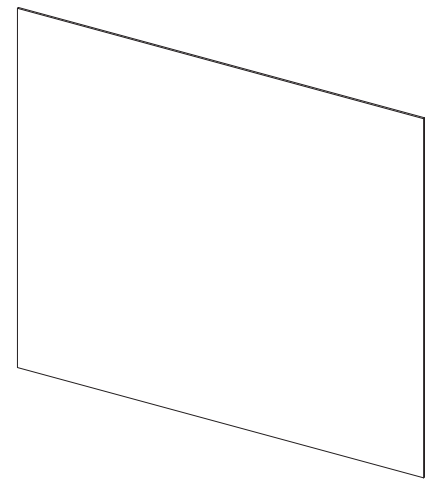

Polycarbonate Roof Panel

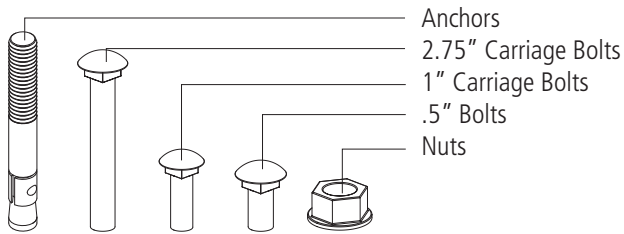

Anchors
2.75" Carriage Bolts
1" Carriage Bolts
.5" Bolts
Nuts

Tools Needed for Installation

- Hammer
- Drill (hammer drill recommended)
- 1/2" masonry drill bit
- 9/16" wrench/socket (2)
- Folding ladder (2)
- 3/8" socket with drill attachment
- 2-3 people



Polycarbonate Panel



Polycarbonate Flange

Rev C



**FOOTING
PLAN**

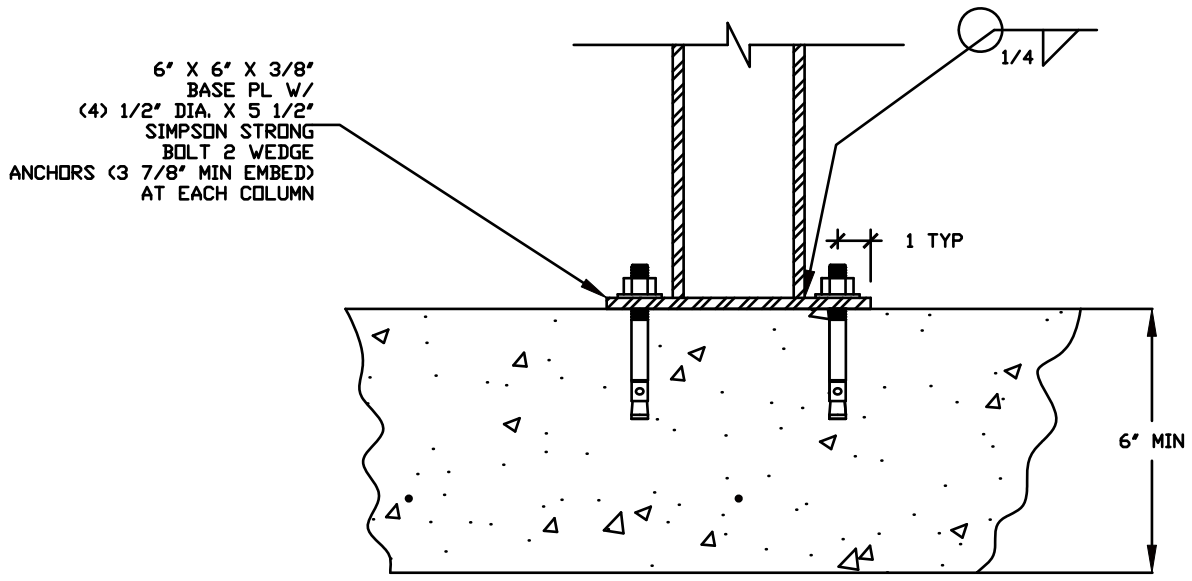
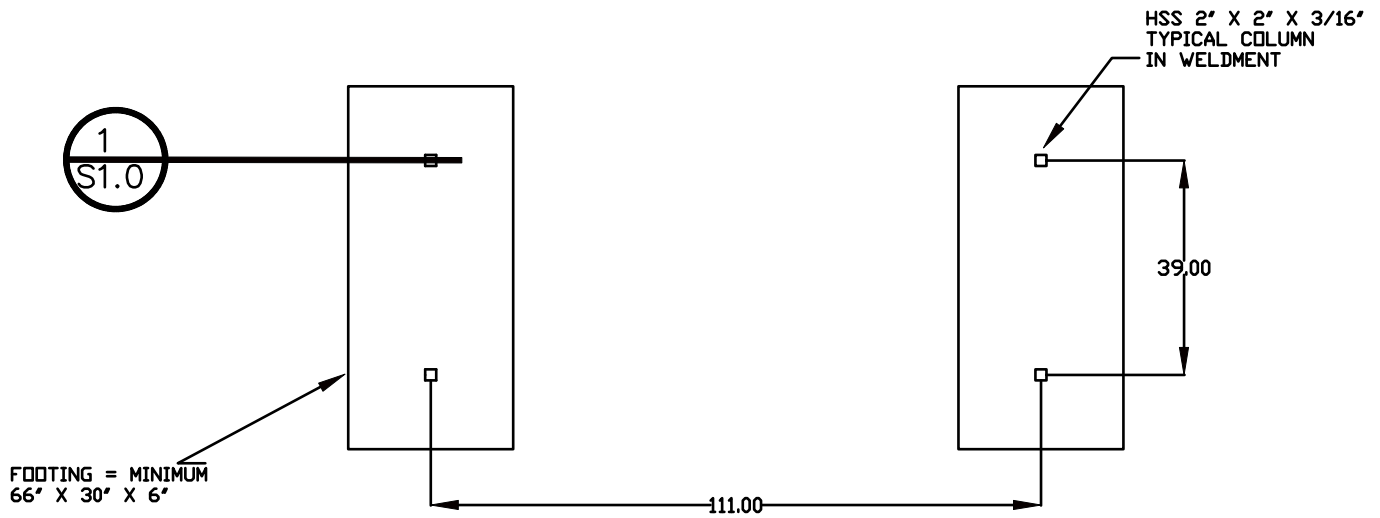

Rev C



- 1** Attach the RAFTER TOP to the UPRIGHT with (4) 3/8" x 1" carriage bolts, nuts and washers. Repeat for all RAFTER TOPS and UPRIGHTS.

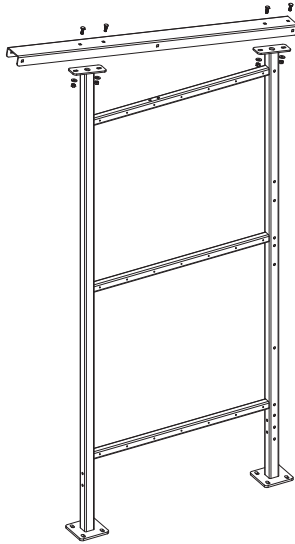

- 2** Stand up the UPRIGHT ASSEMBLIES and attach each PURLIN with (2) 3/8" x 1" carriage bolts, nuts and washers. Continue standing up UPRIGHT ASSEMBLIES and attaching PURLINS if building a modular shelter.

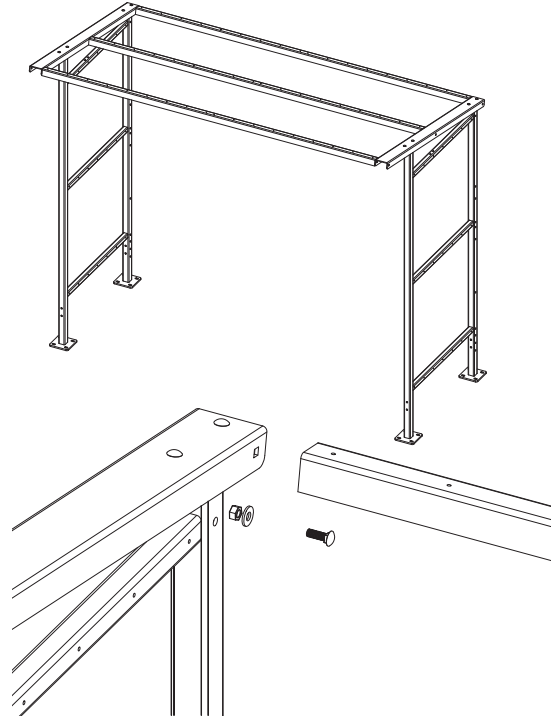

- 3** Attach each REAR PANEL SUPPORT with (2) 3/8" x 3.25" bolts, (4) washers, and (2) nuts. The surface with 21 holes should be facing away from the shelter.

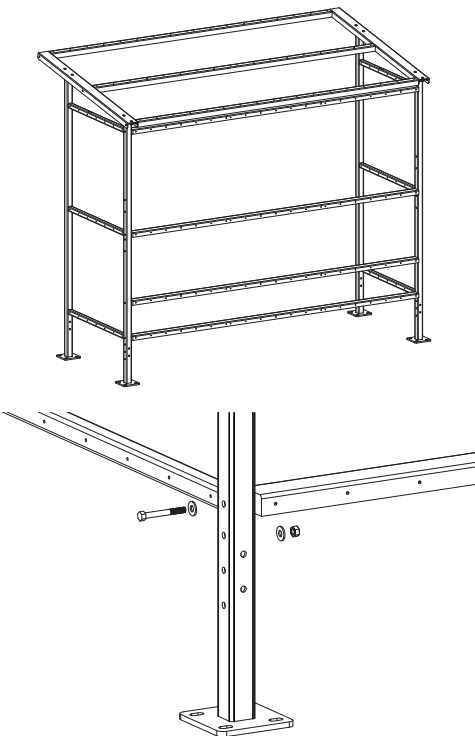

- 4** Using the UPRIGHT feet as a guide, drill 1/2" dia. x 5.5" holes in the concrete footings at each UPRIGHT foot. Install (4) 1/2" dia. x 5.5" wedge anchors at each UPRIGHT foot. See footing diagram for more detail.

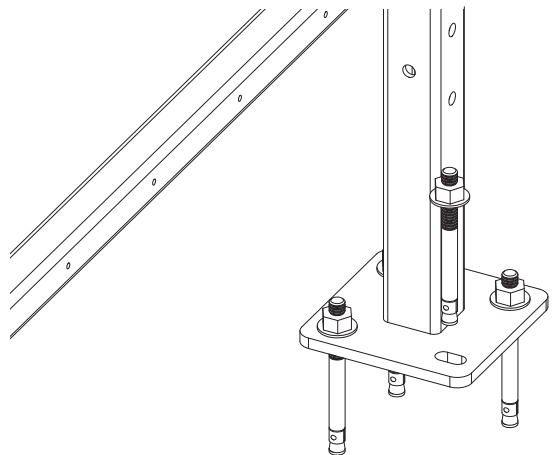

Rev C





1 METAL ROOF

If using metal roofing, place the initial section of TYPE S DECK and secure with (6) ¼" x 1" self-drilling screws. The screws will drill through the TYPE S DECK and shelter without a pilot hole. Place the second section of TYPE S DECK with sufficient overlap and secure with (6) ¼" x 1" self-drilling screws. Continue with the remaining sections. The last section of TYPE S DECK will receive (9) ¼" x 1" self-drilling screws.

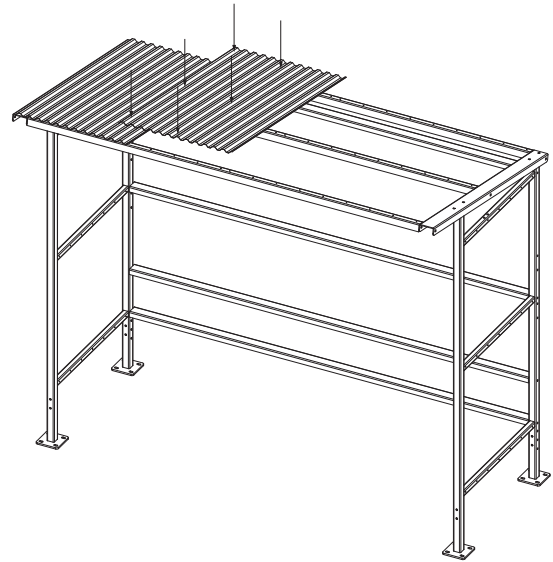
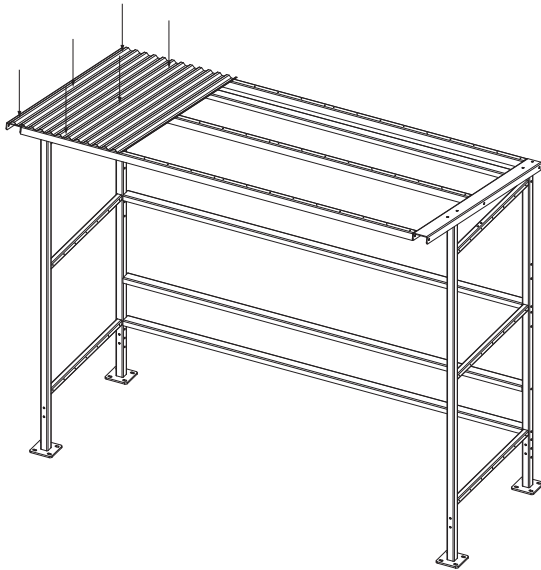

2 POLYCARBONATE ROOF

If using polycarbonate roofing, place POLYCARBONATE ROOF PANELS and POLYCARBONATE FLANGE. After locating a pilot hole in the PURLIN, use a ¼" x 1" self-drilling screw to drill through the POLYCARBONATE ROOF PANEL and into the pilot hole. Confirm the POLYCARBONATE ROOF PANEL is aligned with the shelter and continue with all pilot holes. Use ¼" x 1.5" self-drilling screws when attaching the POLYCARBONATE FLANGE.

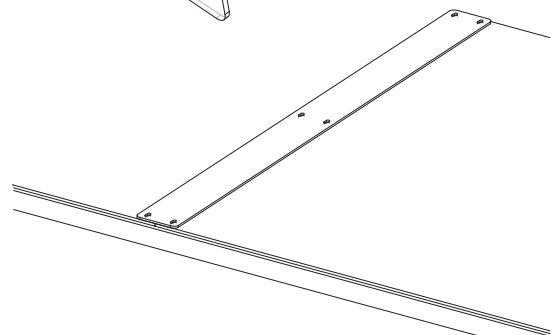
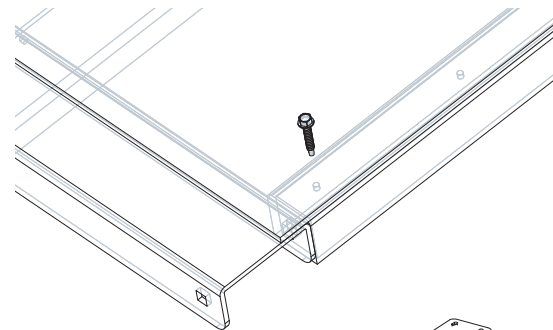
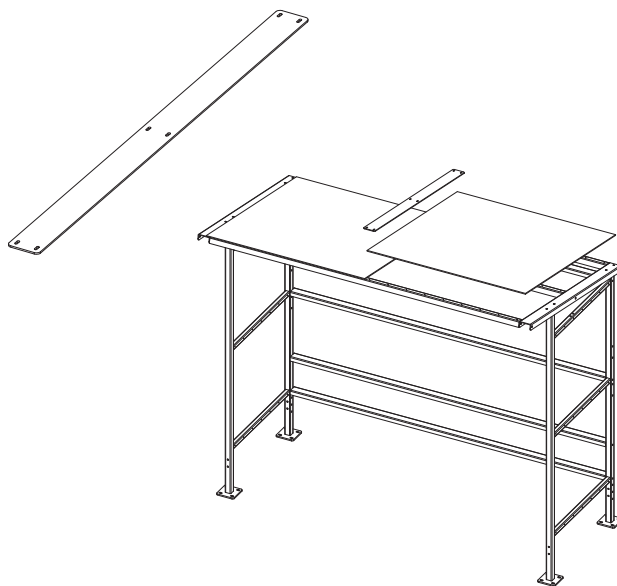

Rev C





- 1 If using Ultra Space Saver racks, assemble the racks, secure each BAR CLAMP to CROSSBARS with (2) 3/8" x 1/2" bolts, lift into place, and secure to shelter with (8) 3/8" x 3.25" bolts, (16) washers, and (8) nuts.

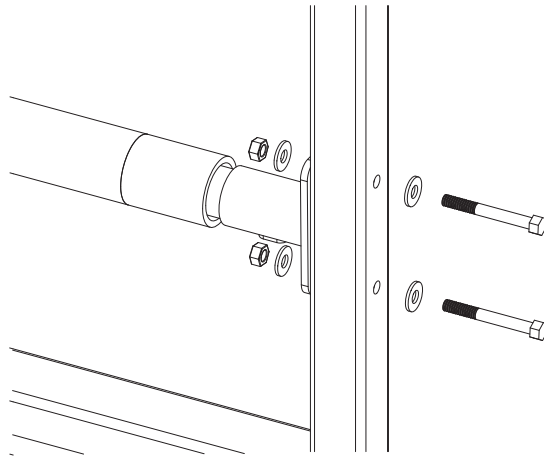
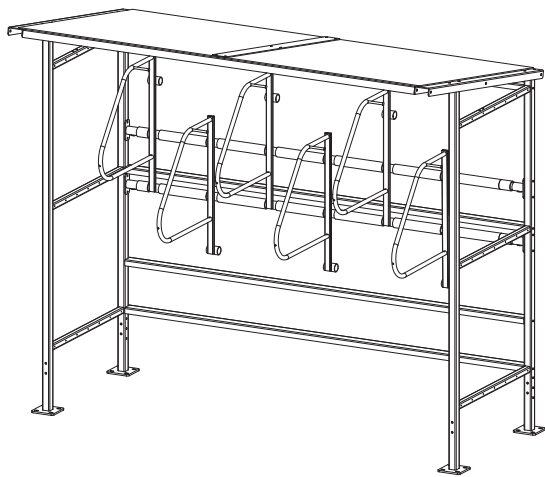
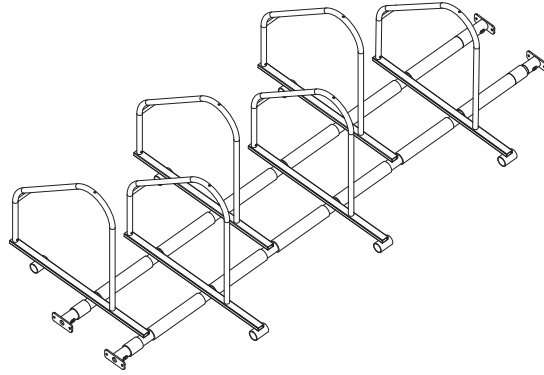
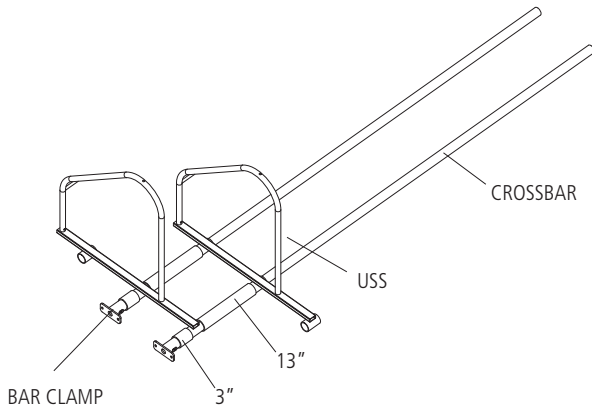



- 1 If using Bike File racks, assemble the racks, lift into place, and secure to shelter with (2) 3/8" x 2.5" tamper-resistant bolts, washers, and Unistrut nuts.

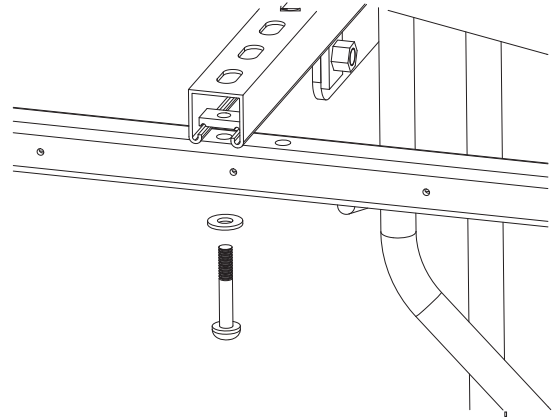
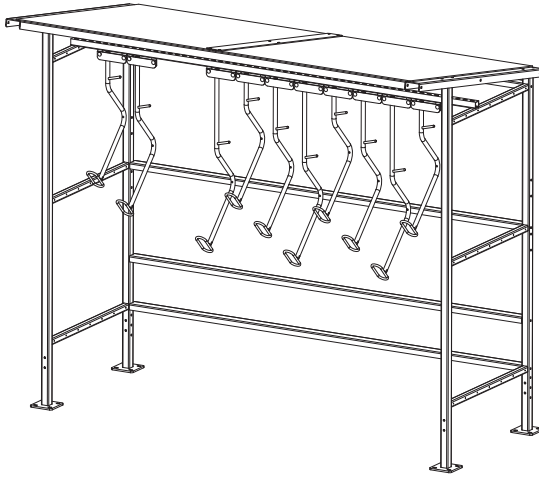



1 SIDE PANELS

If using side panels, place the PANEL with the single pre-drilled hole oriented towards the top. Align the pre-drilled hole and the corresponding pilot hole in the shelter and secure with a $\frac{1}{4}$ " x 1" self-drilling screw. Confirm that the PANEL is aligned with the shelter and not bowed. The next self-drilling screws will drill through the PANEL and into the pilot holes at locations 2 and 3. Continue with the next 18 self-drilling screws while working from the center outwards. Repeat for the other side of the shelter.

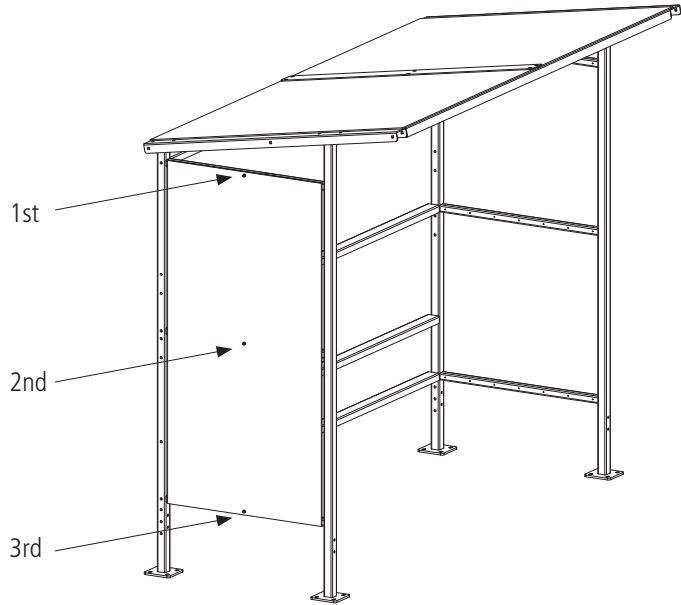
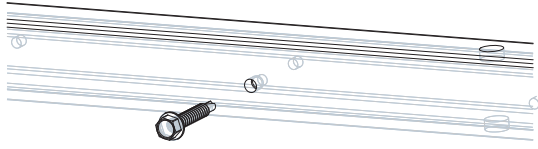

2 REAR PANELS

If using rear panels, place the PANEL with the single pre-drilled hole oriented towards the top. Align the pre-drilled hole and the corresponding pilot hole in the shelter and secure with a $\frac{1}{4}$ " x 1" self-drilling screw. Repeat for the next (2) rear PANELS. Confirm that the PANELS are aligned with the shelter and each other and not bowed. The next self-drilling screws will drill through the PANEL and into the pilot holes at locations 2, 3, and 4. Continue with the next 24 self-drilling screws in each PANEL while working from the center outwards.

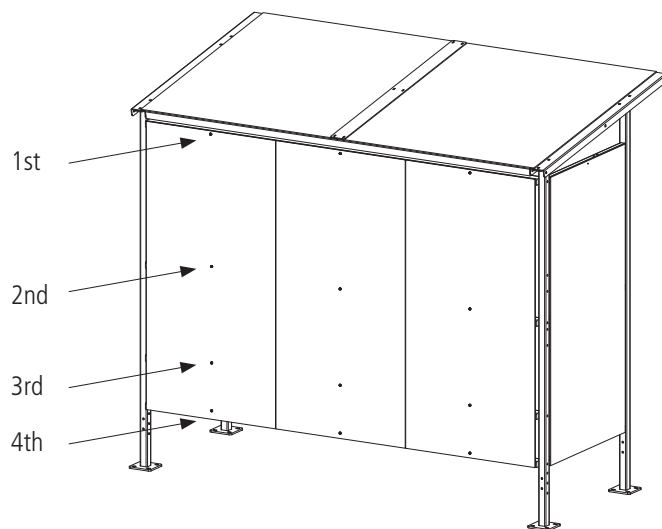
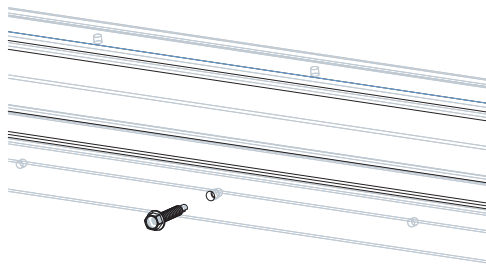



1

To attach a single SIDE BENCH, use (4) 3/8" x 3.25" bolts, (8) washers, (4) nuts, and a SIDE BENCH SPACER.

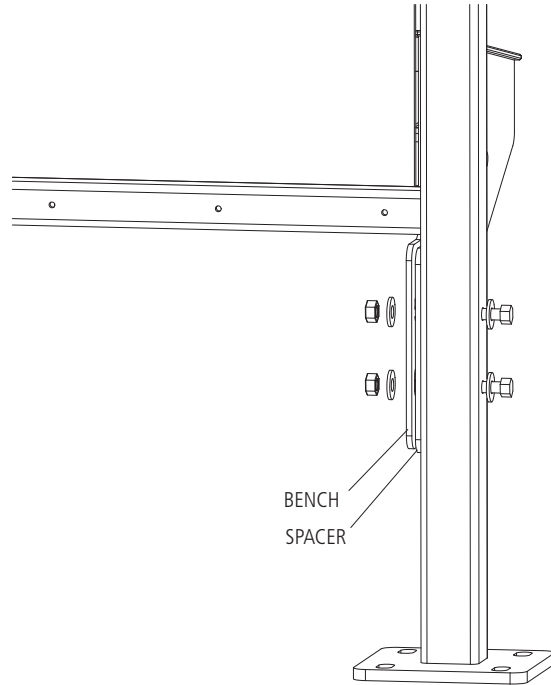
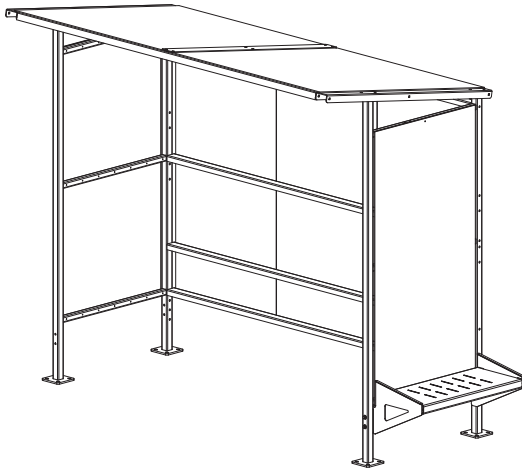

2

To attach two opposing SIDE BENCHES, use (4) 3/8" x 3.25" bolts, (8) washers, and (4) nuts.

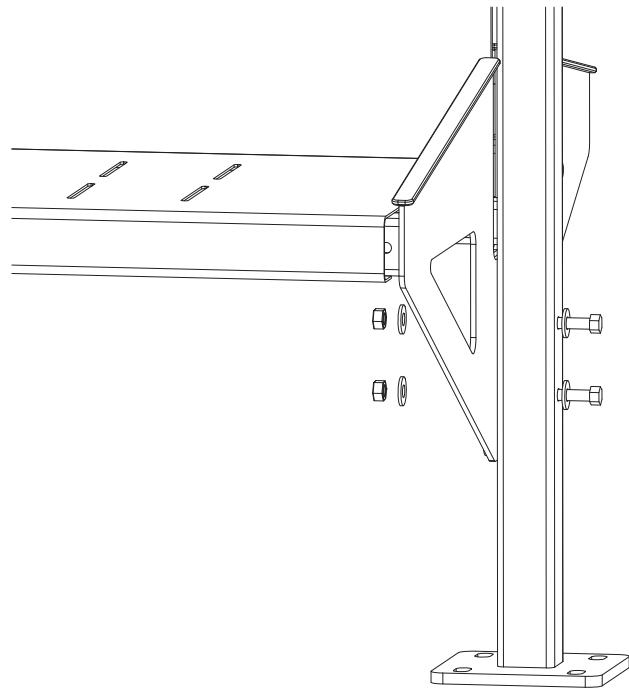
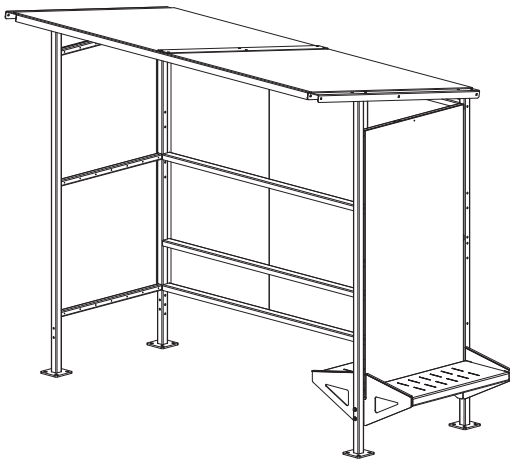

Rev C



3 To attach a single REAR BENCH, use (6) 3/8" x 3.25" bolts, (12) washers, (6) nuts, and a REAR BENCH SPACER.

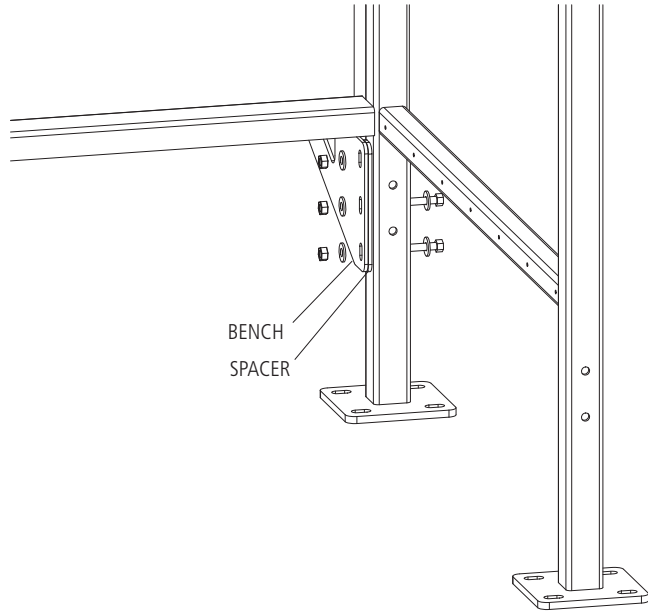
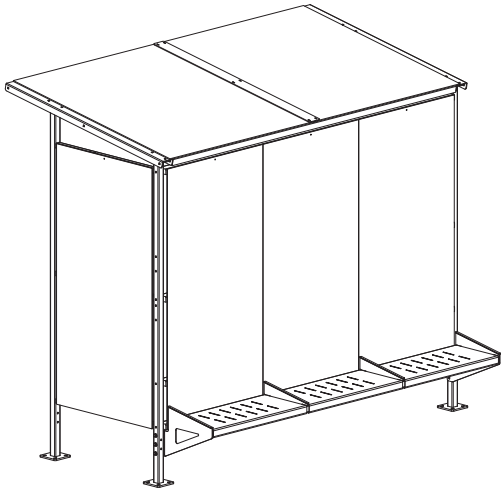

4 To attach two opposing REAR BENCHES, use (6) 3/8" x 3.25" bolts, (16) washers, and (6) nuts.

