



DERO

ULTRA SPACE SAVER SINGLE

- *Secure, out-of-the-way storage*
- *Fender and shock fork compatible*
- *One unit parks one bike*

U-lock compatibility makes this rack great for property managers, commercial parking garages, and for home storage use. The Dero Ultra Space Saver Single Rack's compact design let's you convert otherwise unusable space to bike parking. Quick installation only requires four anchors drilled into the wall. Save room today with the Ultra Space Saver Single, or check out the whole modular Ultra Space Saver system if you need to park many bikes.



DERO
A PLAYCORE Company

 www.dero.com  1.800.337.6729



Printed on recycled paper



ULTRA SPACE SAVER SINGLE

Specifications and Space Use

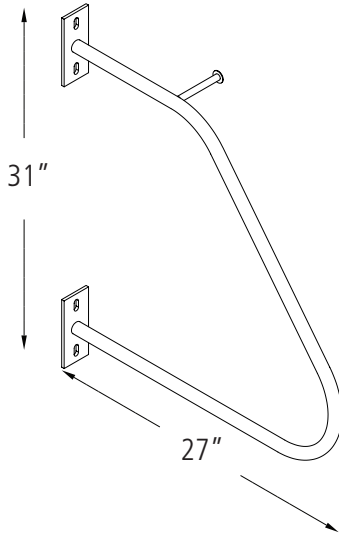



Product Dero Ultra Space Saver Single
As manufactured by Dero Bike Racks

Capacity 1 Bike

Materials  Body is 1" OD 11 gauge tube with 1/2" steel round bar hanger. Mounting flanges are 1/4" plate.

Finishes  Black powder coat
Hanger arm is rubber coated

Installation Methods  **Wall mount** has two 2.5" x 6" foot plates set 25" apart (centerline to centerline) with 4 fasteners. Can be set into concrete block, solid concrete, bricks, wood studs and other base materials .

Space Use and Setbacks  Racks should be placed minimum 16" apart. When installing racks next to each other, their heights should be staggered by 10". See diagram for approximate space use when loaded and recommended setbacks.

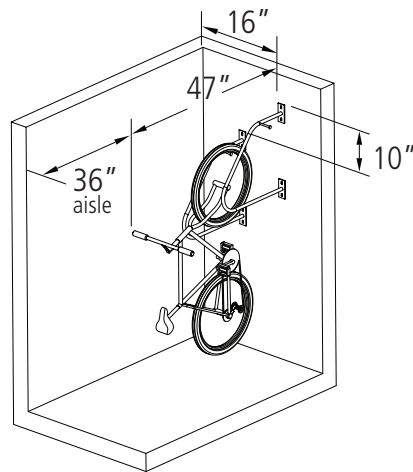

DERO
A PLAYCORE Company



www.dero.com



1.800.337.6729



Tools Needed for Installation

- Tape Measure
- Marker or Pencil
- Masonry Drill Bit
- Drill (Hammer drill recommended)
- Hammer
- Wrench or ratchet 9/16"
- Level

Recommended Base Materials:

Solid concrete is the best base material. Brick, block, and wood stud walls may be acceptable. Metal stud walls are not an acceptable material for installation. Before installing make sure nothing is behind the wall that could be damaged by drilling and that the base material is strong enough to support a fully loaded rack. Tell your Dero representative what kind of base material you are installing the Wall Rack into so the proper anchors can be shipped with the rack.

Installation:

3/8" anchors are shipped with the rack. Place the rack in the desired location. Use a marker or pencil to outline the holes of the flange onto the base material. Drill the holes in accordance with the specifications shipped with the anchors. Make sure the holes are at least 3" away from any cracks in the base material.

Tamper Resistant Fasteners

The concrete spike is a permanent anchor. The top of the wedge anchor can also be pounded sideways after installation so that it cannot be removed. Other tamper resistant fasteners are also available for purchase.

When using the special tamper resistant nuts, always set and first tighten the anchors. Once the rack is installed, replace two nuts from the bracket (opposite sides from each other) with the tamper resistant fastener. DO NOT OVERTIGHTEN the tamper resistant nut.



If you have any questions about installation or other features of the Ultra Space Saver Single, please call us toll free at 1-800-298-4915

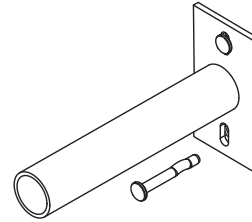

Concrete Spike

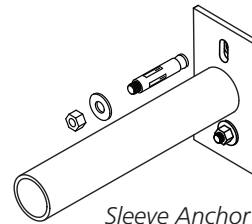

Sleeve Anchor



Titen Anchor

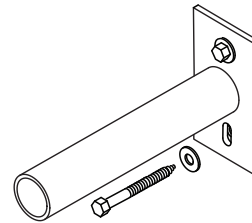

Lag Screw
(wood install)



Breakaway Nut



Stainless Tamper-Proof Nut



Triple-slot Nut



Concrete Spike





Tools Needed for Installation:

- 9/16" socket or wrench
- Hammer
- Drill (Hammer drill works best)
- Level
- Marker or Pencil

Installation Steps

- 1** Place rack against wall. Mark holes and lower rack.
- 2** Drill holes 2" deep with 1/2" diameter drill bit. If installing more than one Ultra Space Saver Single, mark holes for each rack individually as there may be slight differences in the placement of holes from rack to rack.
- 3** Place rack back into position against wall and tap anchors through holes in the rack and into the wall.
- 4** Tighten anchors

1

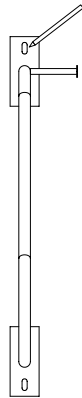

2

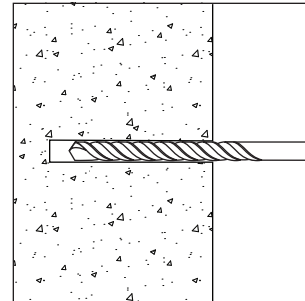

3

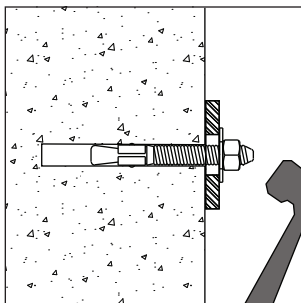

4

