

- (A) (12) 1/4" SELF-DRILL SCREWS
- (B) (4) 1/2" BOLTS
- (C) (4) 1/2" BOLTS
- (D) (4) 1/2" DIA. SIMPSON STRONG BOLT 2 ANCHORS
3.5" MIN. EMBEDMENT

- (1) UPRIGHT BACK WELDMENT
- (2) TRUSS WELDMENT
- (3) UPRIGHT FRONT WELDMENT
- (4) PURLIN WELDMENT
- (5) TYPE S DECK 2.5 X .5625



TOOLS NEEDED

- Tape Measure
- Level
- Hammer Drill
- Large Hammer
- Chalk Line
- Masonry Bits: 3/8", 1/2"

- Material Lift or Fork Lift
- Wrenches: 9/16", 3/4"
- Socket Wrench with Sockets: 7/16", 1/2", 9/16", 3/4"
- Drive Socket 5/16"
- Tall Ladder.

1

Customer is responsible for preparing the slab with minimum strength of 3,000psi as shown.

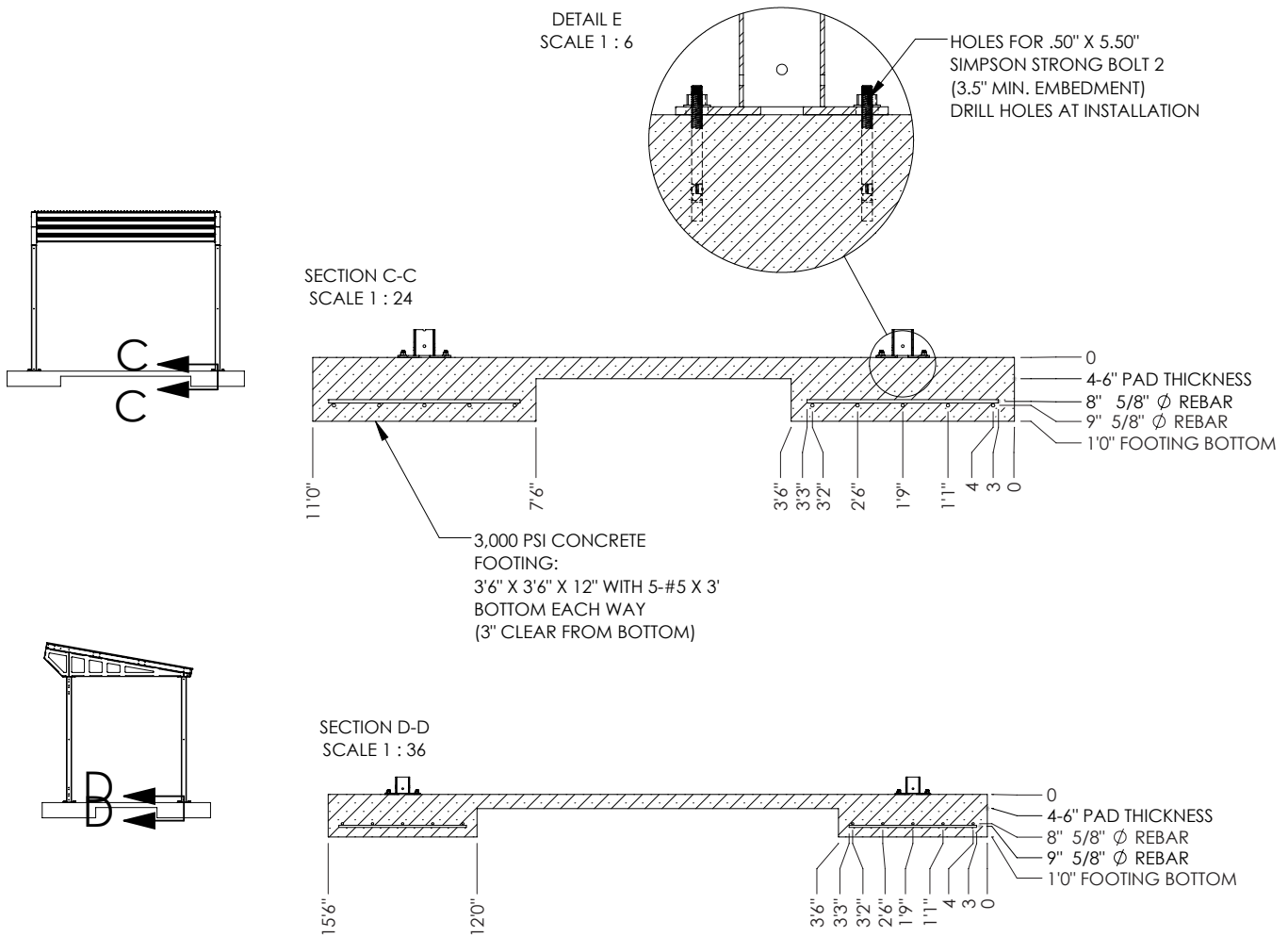

SECTION A-A
SCALE 1 : 36

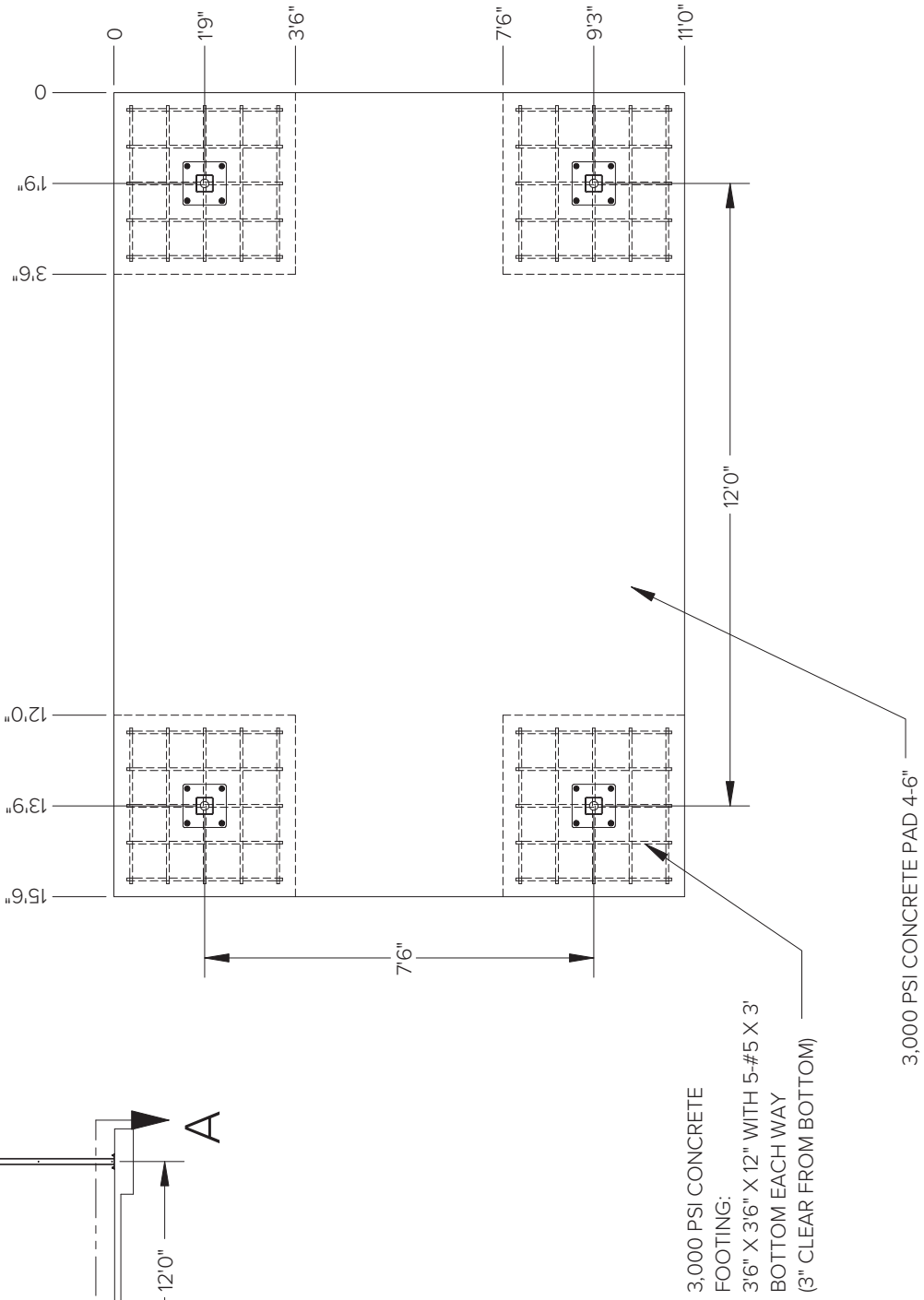
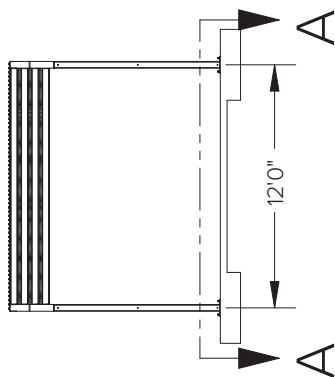

SIZE	DWG. NO.	REV.
A	3000328-A	A
SCALE: 1/36		SHEET 3 OF 12

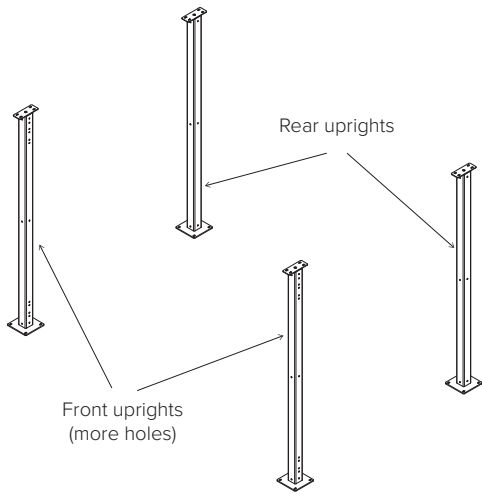
2

Place uprights on concrete pad over footings (see step 1). Confirm all uprights are properly spaced and square. Using the upright foot as a template, drill (4) 1/2" diameter x 6" holes at each upright. Install wedge anchors with nuts finger-tight. See shelter assembly drawing for specific upright placement locations. If there's an elevation change at the uprights, a non-shrink, 3,000 psi. grout pad may be used. Longer anchors may be needed to maintain a 3.5" min. embedment.

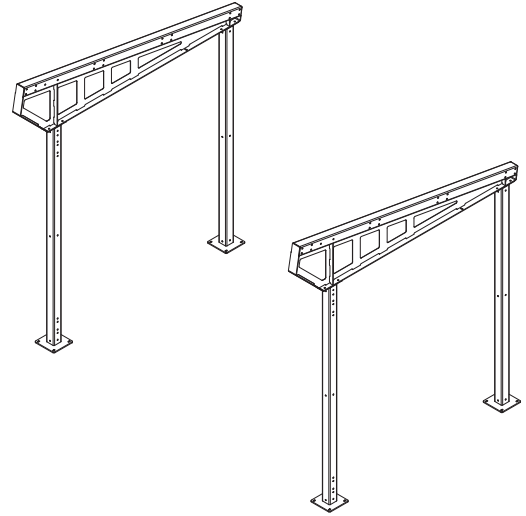
3

Lift trusses into place and fasten to uprights with (4) 1/2" x 1.5" carriage bolts, (4) lock washers, and (4) nuts at each upright. Leave finger-tight.

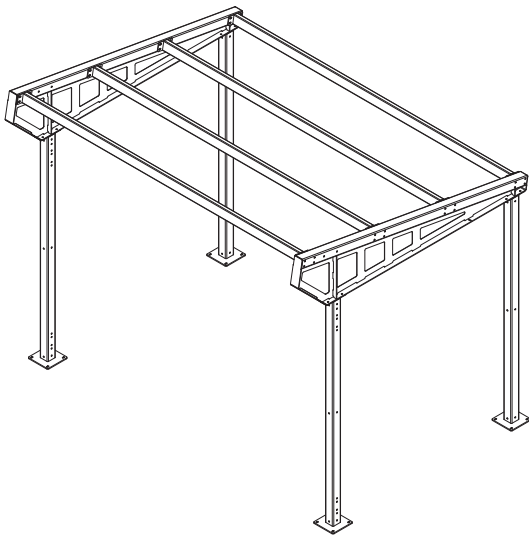
4

Install the purlins with (8) 1/2" x 5.5" bolts, (16) lock washers, and (8) nuts each. Fully tighten after all purlins are in place.

Tighten all upright and truss bolts.

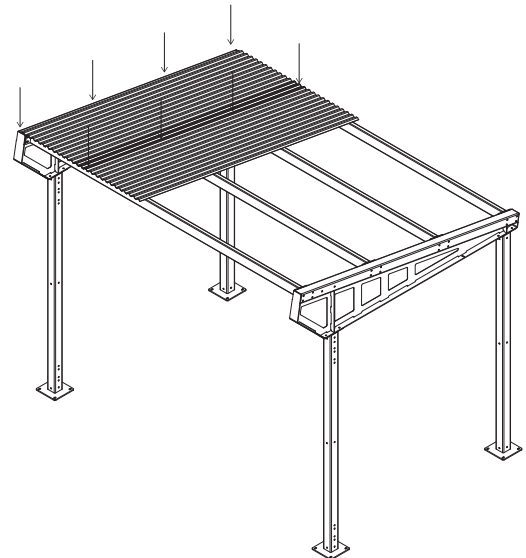
5

Place the first section of type S decks and fasten with (4) self-drilling screws to the truss. Place the next section of type S decks with 3 ridges overlapping and fasten with (4) self-drilling screws through both sections to the purlins. Each deck will provide 27.5" of coverage. Continue until done. The last section will require (8) self-drilling screws.

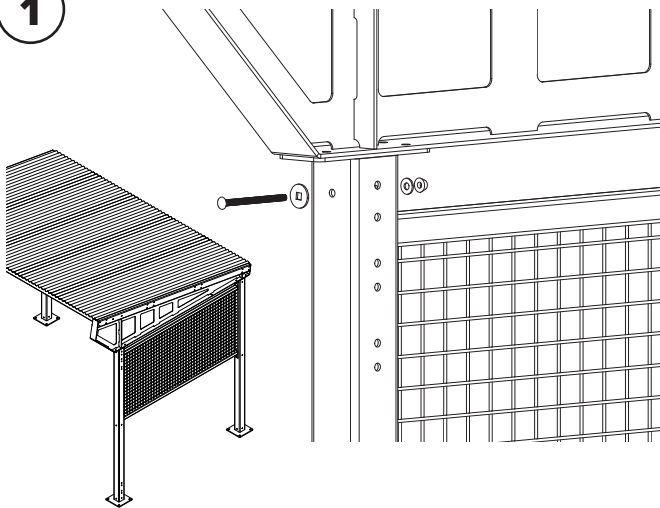
1

Place a side panel in the upper position and attach with (2) 3/8" x 5.5" carriage bolts, (2) 3/8" carriage bolt washers, (2) 3/8" washers, and (2) Penta nuts. Leave finger tight.

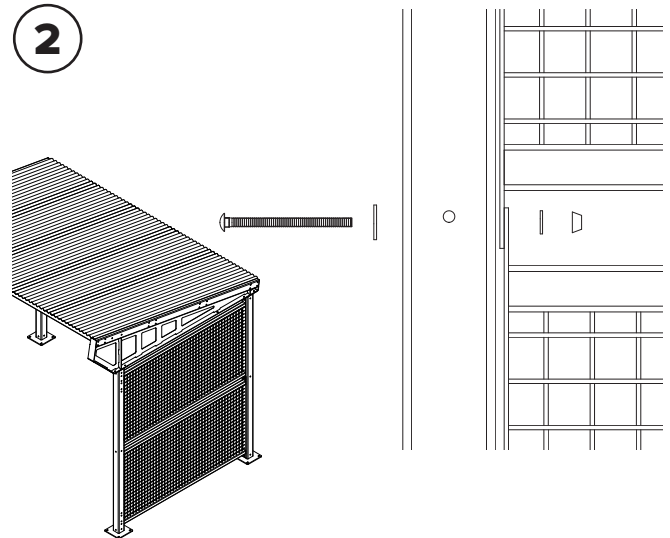
2

Place a side panel in the lower position and attach with (4) 3/8" x 5.5" carriage bolts, (4) 3/8" carriage bolt washers, (4) 3/8" washers, and (4) Penta nuts. Tighten all (6) bolts.

Place and attach the remaining side panels.

Place and attach the rear panels with the same method as the side panels.

3

Place and attach the upper front panel in the correct position depending on whether front doors or panels are present.

Front Panel Mounting Location

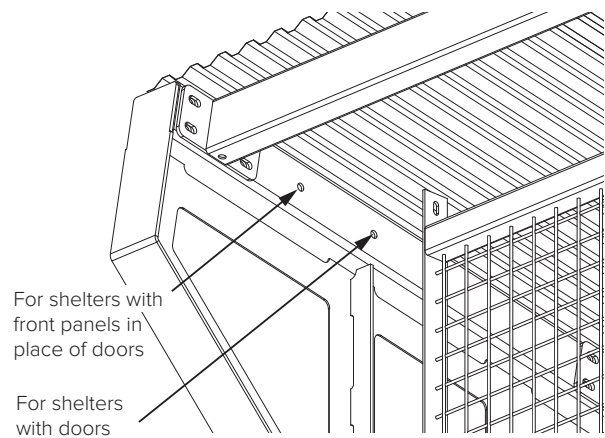
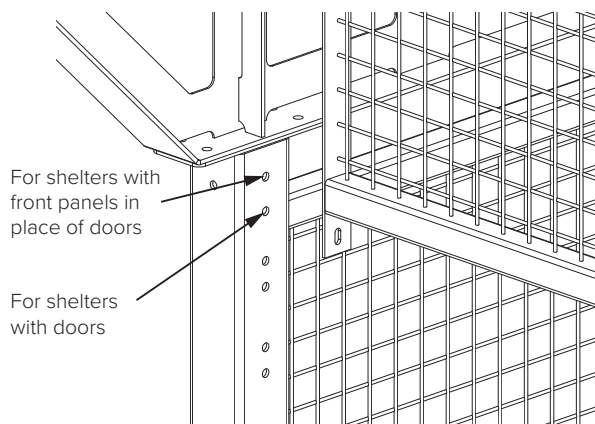

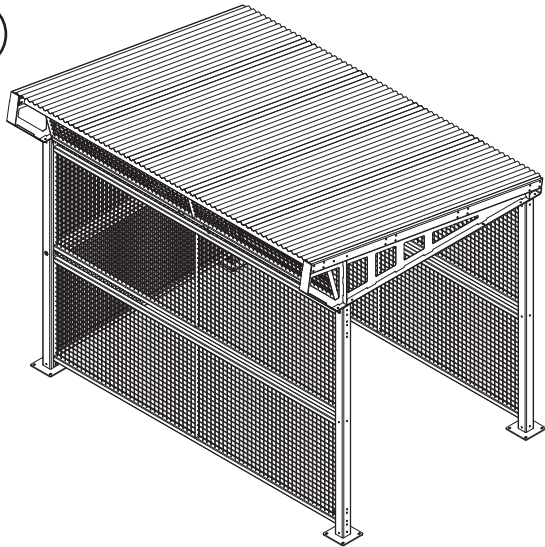
4

For shelters with front panel in place of doors, attach rear panels in the front of the shelter.

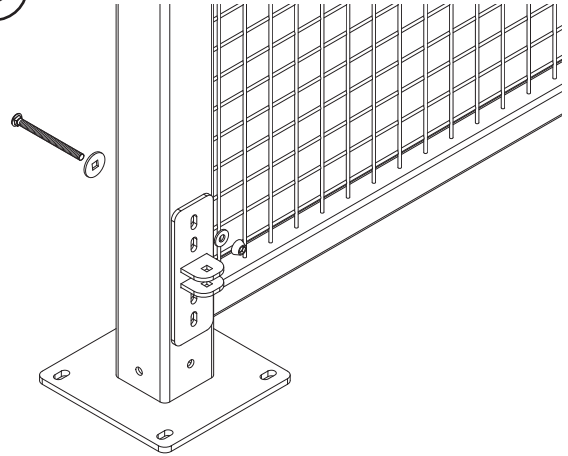
5

Attach (4) hinges with (4) 3/8 x 5" carriage bolts, (4) 3/8" carriage bolt washers, (4) 3/8" washers, and (4) Penta nuts at each hinge. If the uprights are not perfectly vertical, a washer may be placed between the hinge and upright to align the axis of the hinges. Leave the bolts finger-tight.

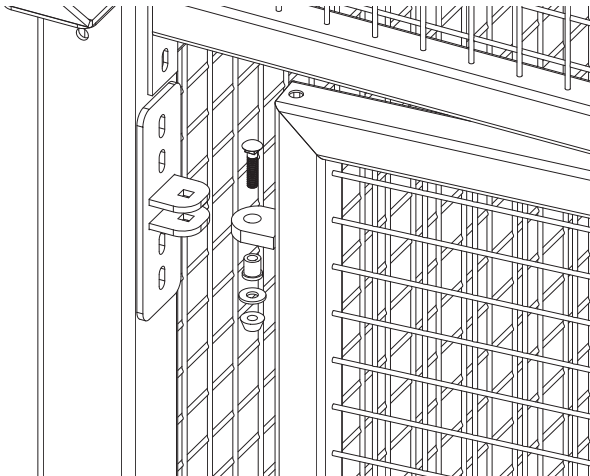
6

Attach the doors with (1) 3/8 x 1.75" carriage bolt, (1) brass sleeve bearing, (1) 3/8" washer, and (1) Penta nut at each hinge. Tighten the Penta nuts. Then tighten hinge Penta nuts.

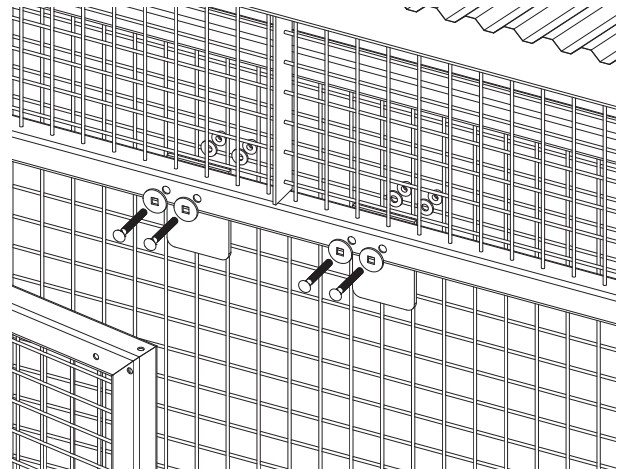
7

Attach both upper door stops with (2) 3/8 x 3" carriage bolts, (2) 3/8" carriage bolt washers, (2) 3/8" washers, and (2) Penta nuts at each stop.

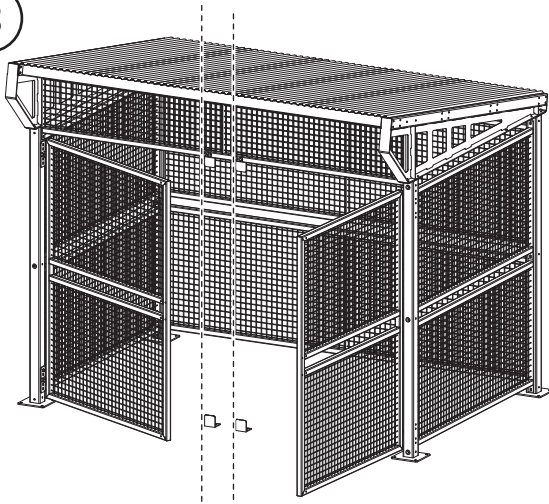
8

Line up top and bottom door stops

Anchor the lower door stops to the concrete with (2) 3/8 x 3" wedge anchors and (2) Penta nuts in place of the hex nuts. The lower door stops should be directly below the upper door stops and just contact the door when it's closed. The left and right lower door stop may be placed slightly off to accommodate some distortion in the doors.

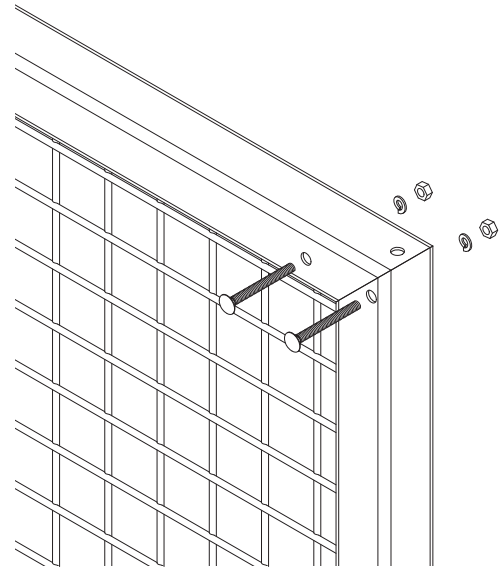
9

Fill the (8) 3/8" holes in the left door with (8) 1/4 x 2.5" carriage bolts, (8) lock washers, and (8) nuts.

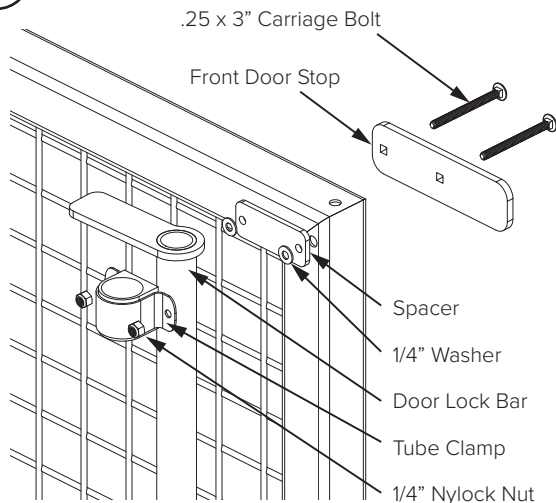
10

Attach the door lock bar to the right door with (8) 1/4 x 3" carriage bolts, (4) front door stops, (4) spacers, (8) washers, (4) tube clamps, and (8) nylock nuts. Once bolts are tightened the lock bar should rotate freely.

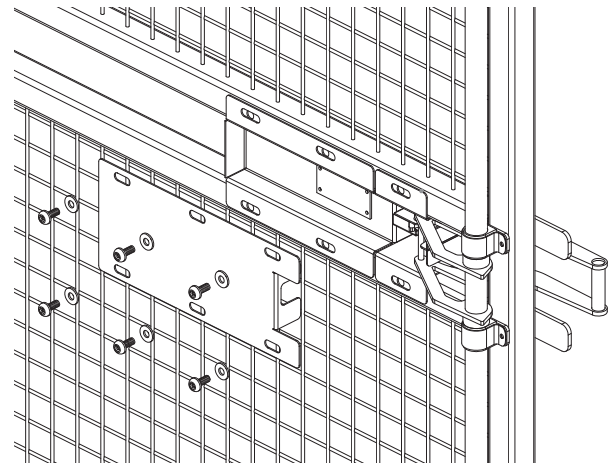
11

Attach the latch assembly and cover with (6) 3/8 x 1" security bolts, and (6) 3/8" washers. The latch assembly can be laterally positioned so the lock bar strike enters and exits the latch smoothly.