

5 Locker Assembly

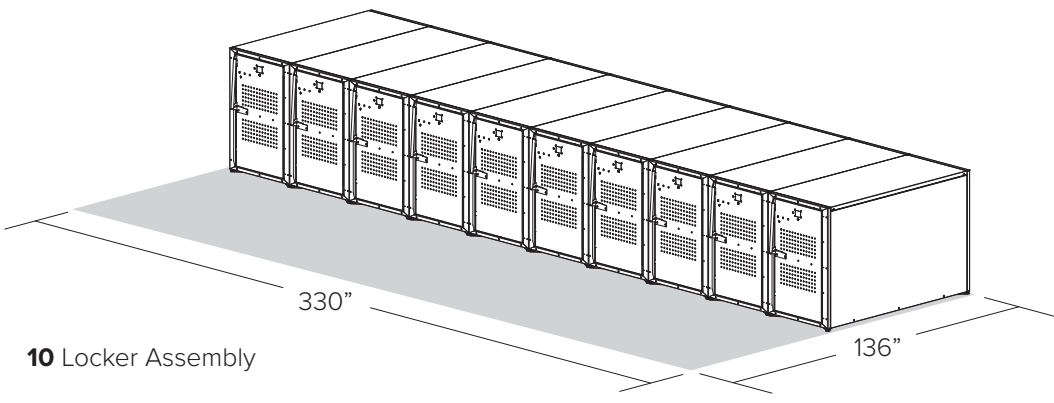

10 Locker Assembly



TOOLS NEEDED

- Hammer drill with 3/8" masonry bit
- Hammer
- Bubble level
- Tape measure
- 3/8", 7/16", 1/2", 9/16" wrenches
- Socket wrench
- 3/8", 7/16", 1/2", 9/16" sockets
- Power drill
- #3 Phillips screwdriver bit
- Needle-nose pliers
- Socket Extension
- Small side-cutter pliers

RECOMMENDED BASE MATERIAL

Solid concrete is the best base material for installation. To ensure the proper anchors are shipped with your locker, ask your Dero representative which anchor is appropriate for your application. Be sure nothing is underneath the base material that could be damaged by drilling.

1

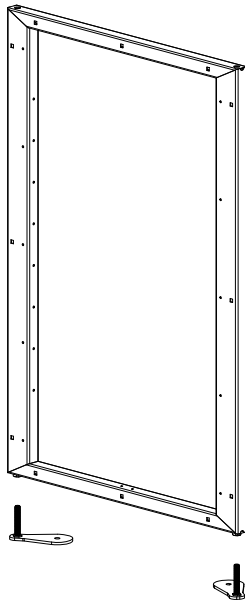

Thread (2) leveling feet into each door frame.

2

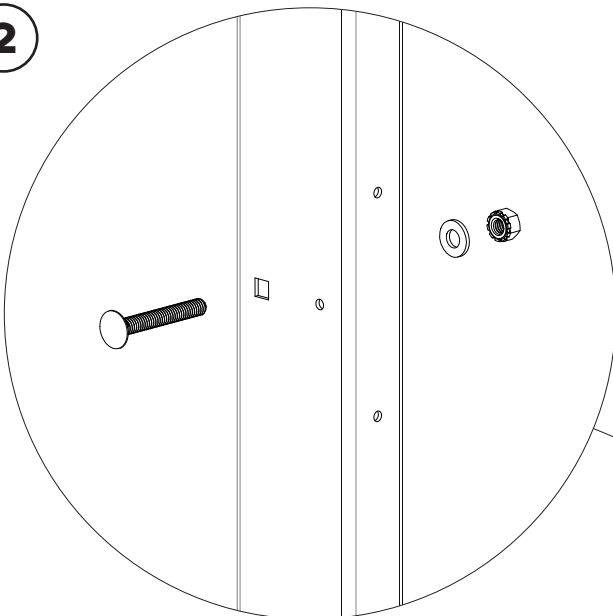

Attach (2) side panels to the (2) door frames with (12) 5/16" x 2.25" carriage bolts, washers, and nuts. Omit the (4) bottom bolts for now. Leave nuts finger-tight

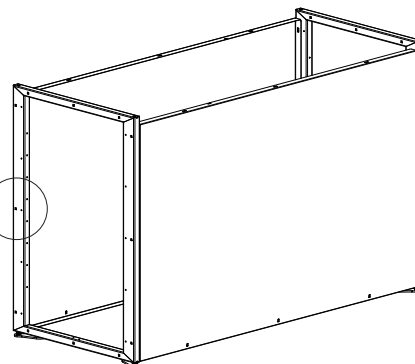

3

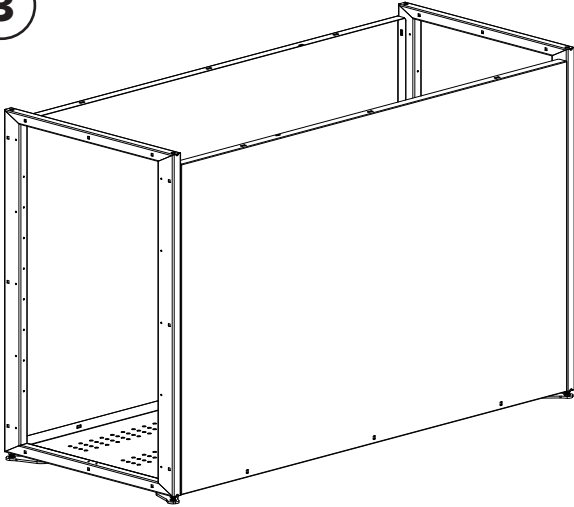

Place the floor panel in the locker and attach to the side panels with (6) 5/16" x .75" carriage bolts, washers, and nuts. Attach to the door frames with (6) 5/16" x 2.25" carriage bolts, washers, and nuts. Add the remaining (4) 5/16" x 2.25" carriage bolts, washers, and nuts that attach the side panels to the door frames. Leave all nuts finger-tight.

4

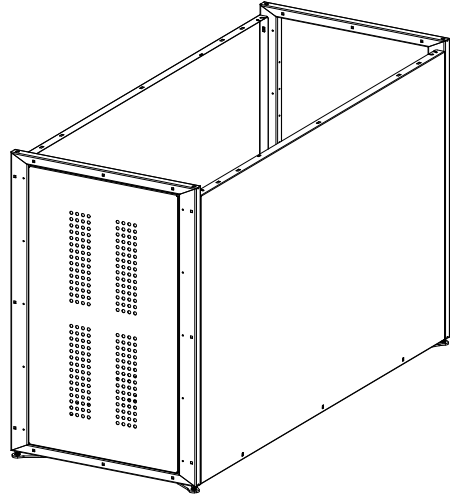

Attach the back panel to the rear door frame with (10) #12 x 3/4" self-drilling screws. Pilot holes are present but may be partially filled with zinc. Screwing is done from inside the locker. Set the power drill clutch to a high setting but not locked. The final tightening should be done by hand with a #3 Phillips driver. **Do not use an impact drill** or the threads will be stripped.

5

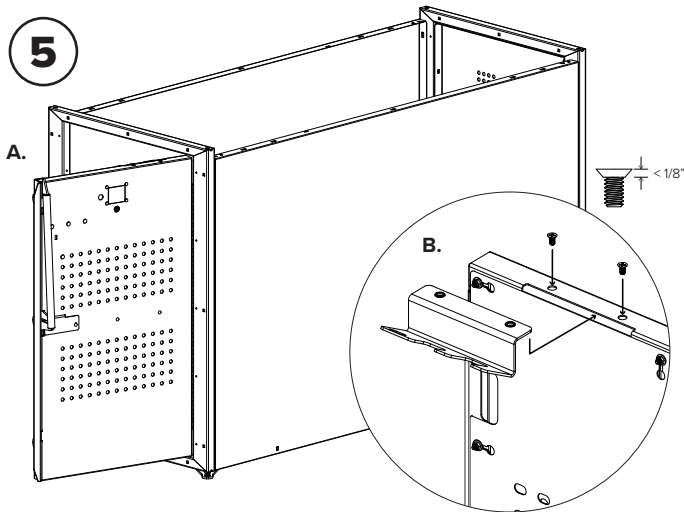

A. Attach the door assembly with (8) #12 x 3/4" self-drilling screws. Pilot holes are present but may be partially filled with zinc. Set the power drill clutch to a high setting but not locked. The final tightening should be done by hand with a #3 Phillips driver. **Do not use an impact drill** or the threads will be stripped.

B. Attach the door spring/gear hook to the door with (2) 1/4" x 1/2" undercut screws.

6

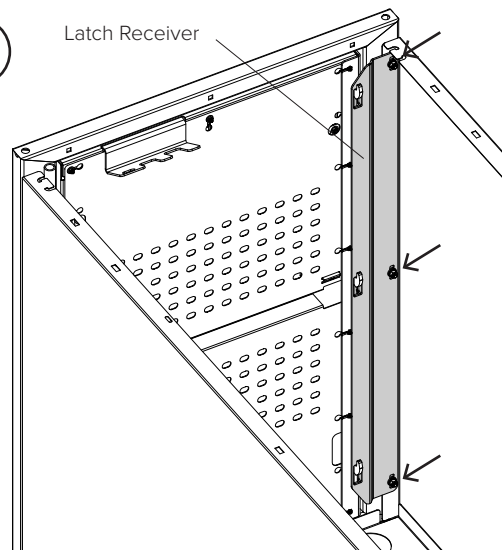

Attach the latch receiver by removing the (3) nuts on the inside-left of the door frame (these are the nuts that hold the side panel on). Place the latch receiver on the (3) bolts and fasten with the (3) nuts finger-tight.

7

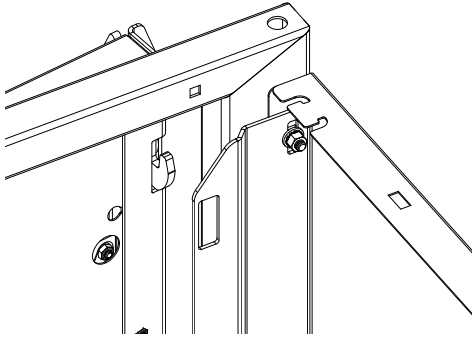

A

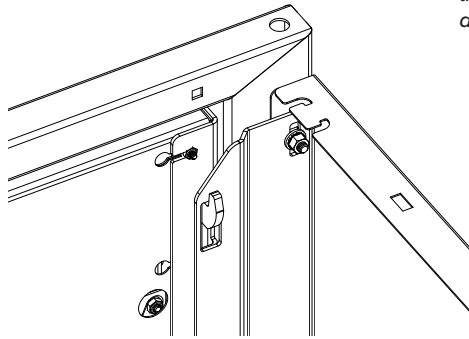

B

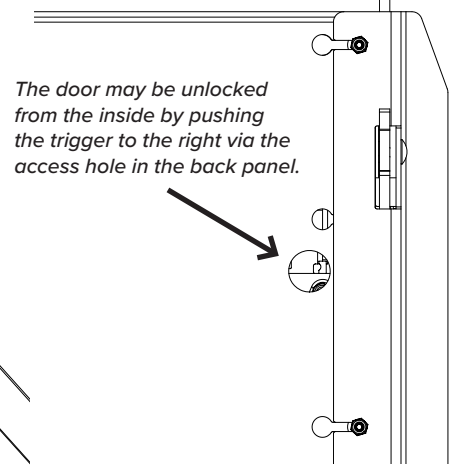

The door may be unlocked from the inside by pushing the trigger to the right via the access hole in the back panel.

C

Unlock the door so the latch is lowered and shut the door. Confirm the latch hooks can pass through the slots in the latch receiver. Lift the door handle and confirm the latch locks without interference from the receiver. Tighten the (3) nuts attaching the latch receiver. Confirm the unlock and lock procedure one final time.

8

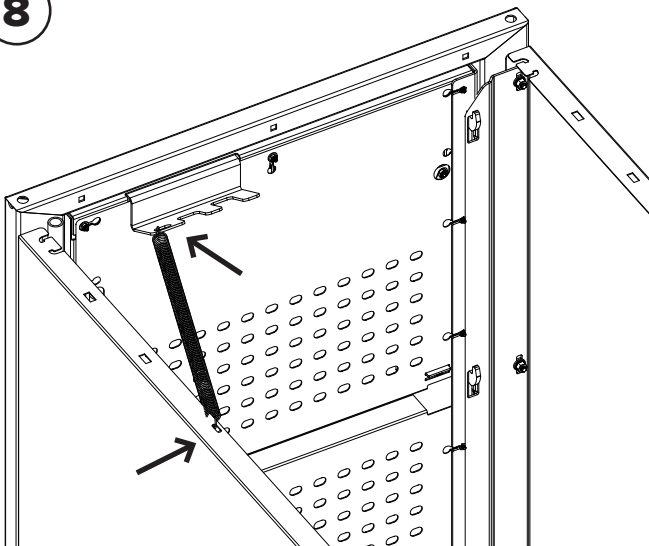

Attach the door closing spring to the door spring/gear hook bracket and side panel. A needle-nose pliers is helpful.

9

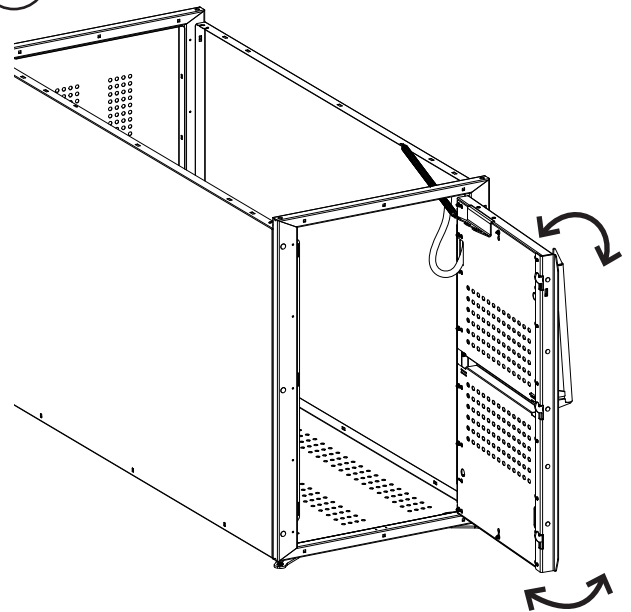

If any twist needs to be taken out of the door, loosen the #10 locknuts, set the door, and re-tighten.

10

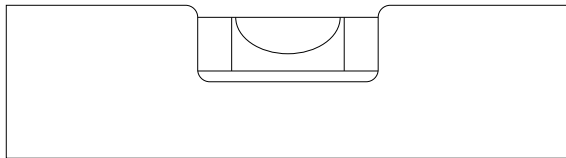

Level the locker with the leveling feet, check squareness, and tighten all the 5/16" nuts attaching the side panels, door frames, and floor.

11

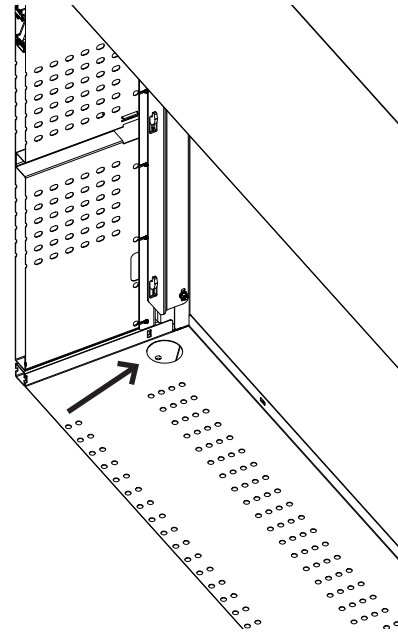

Secure the locker to the ground with (4) anchors. The leveling foot anchor holes should line up with the large holes in the locker floor.

Use wedge anchors for installation on concrete, or Titen anchors for asphalt surfaces. Contact Dero if you do not have the appropriate anchors for your installation surface.

12

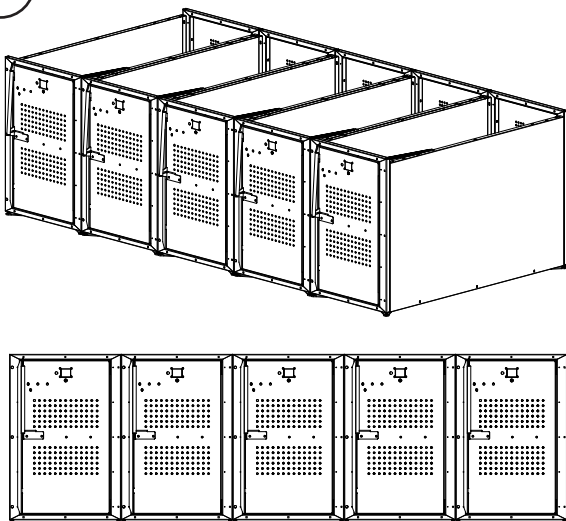

If a row of lockers is to be installed, build the others in the same way and position them directly next to each other with all lockers in a row at the same height. None of the lockers have roofs at this point.

13

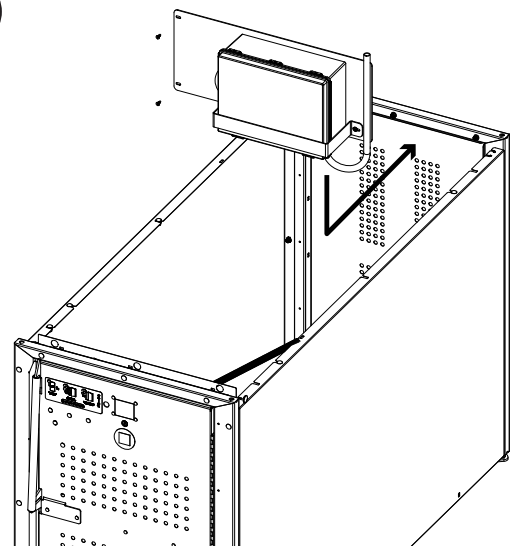

The first locker will contain the Bikeep main control unit (MCU). Place the MCU holder against the back frame and secure with (4) #12 x 3/4" self-drilling screws and washers. Pilot holes are present but may be partially filled with zinc. Screwing is done from inside the locker. Set the power drill clutch to a high setting but not locked. The final tightening should be done by hand with a #3 Phillips driver. Do not use an impact drill or the threads will be stripped.

14

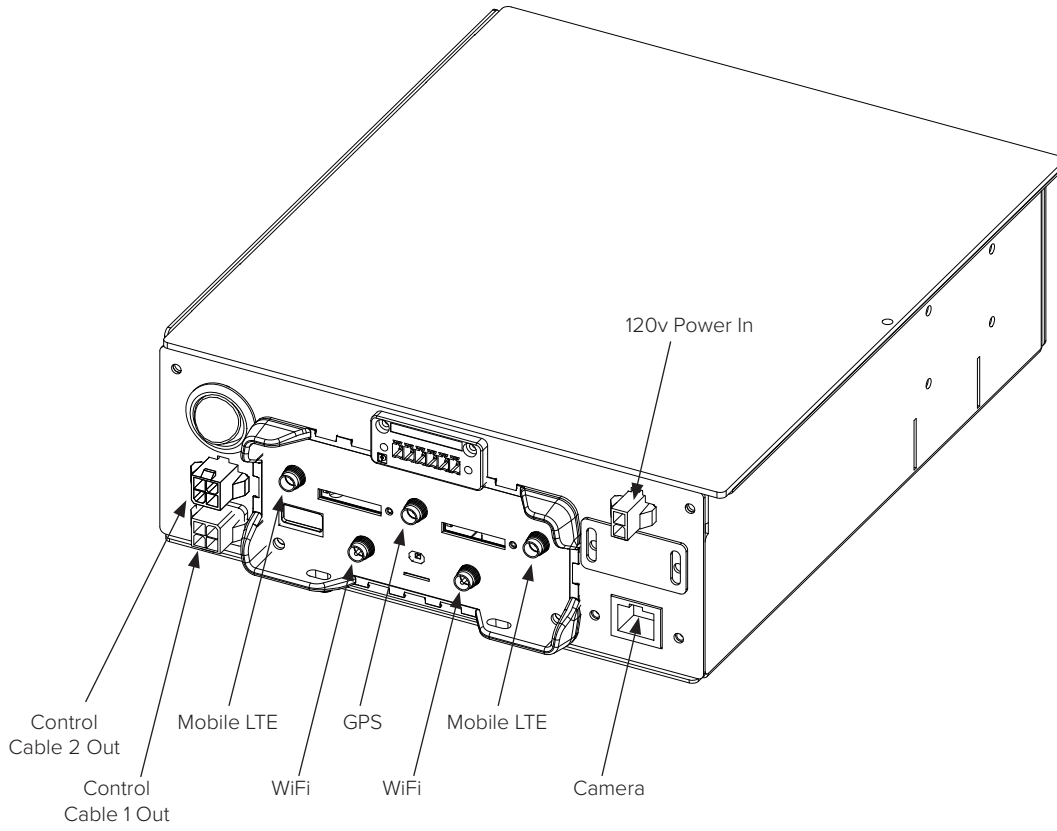

15

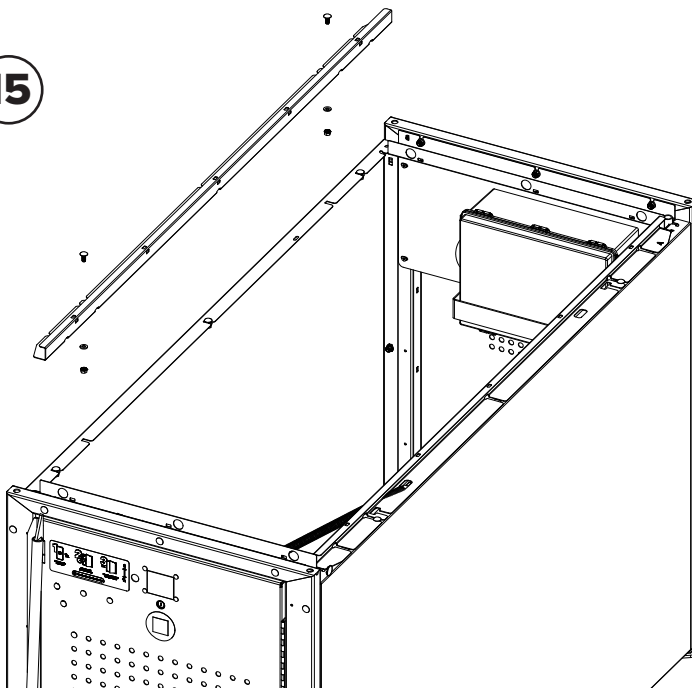

Attach the (2) side cable guards and secure with (2) 5/16" x 3/4" carriage bolts, washers, and lock nuts. Note the specific holes.

16

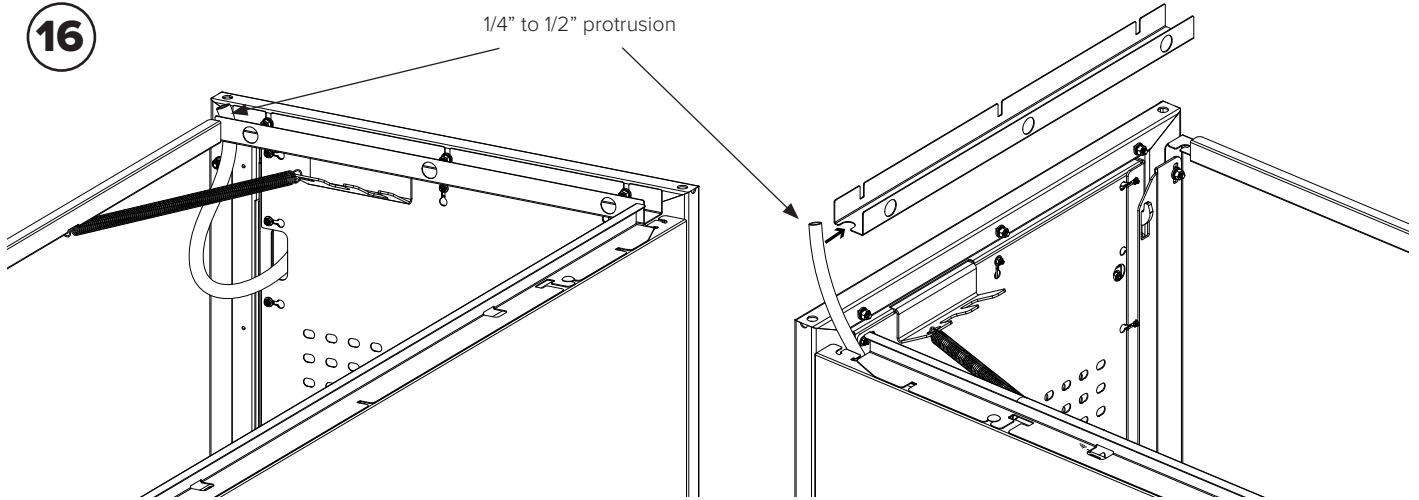

Attach the front cable guard and secure with (3) 5/16" x 2.25" carriage bolts, washers, and nuts. Before placing the front cable guard, slide the flexible conduit from the door into the side slot of the cable guard. When the cable guard is secured, the flexible conduit should be held captive. Give it a tug to confirm.

17

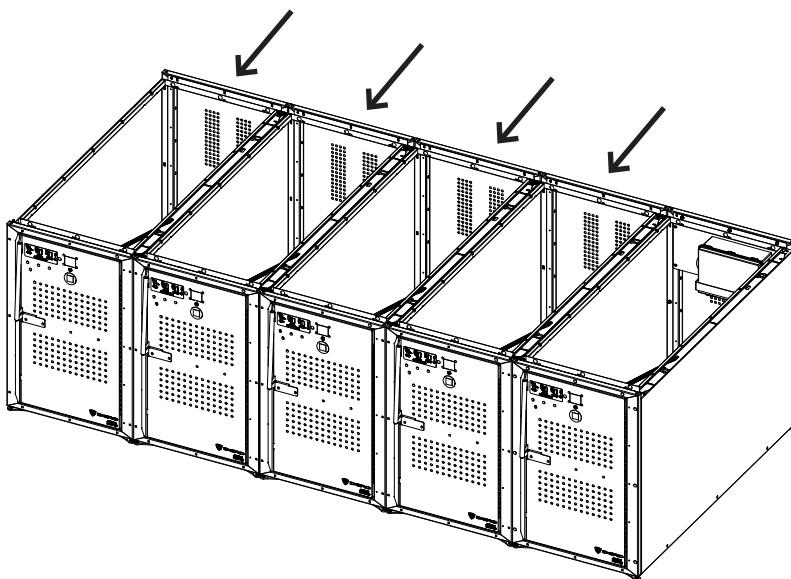

Repeat steps 15-16 for the remaining lockers in the set. In addition, a front cable guard is secured to the top of each rear frame. Before placing the initial rear cable guard, slide the flexible conduit from the MCU box into the side slot of the cable guard. When the cable guard is secured, the flexible conduit should be held captive. Give it a tug to confirm.

18

Place the short lengths of flexible conduit at the front and rear of lockers where they are adjacent. Use zip-ties with the cutout features in the side panel to loosely hold them in place.

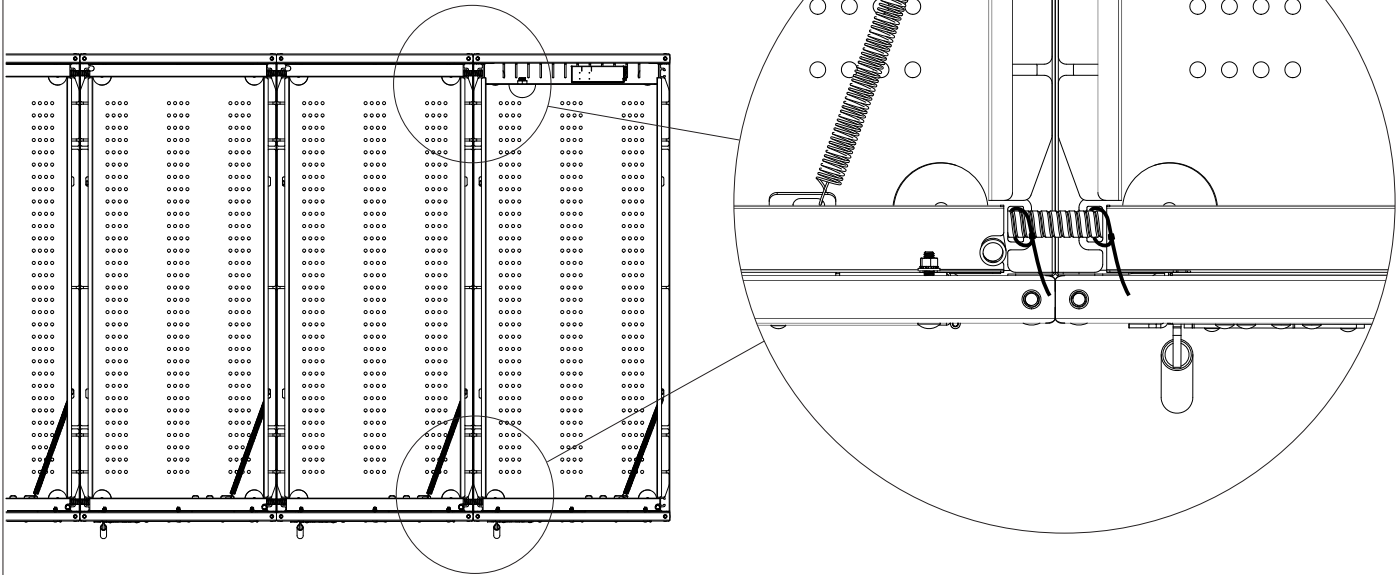

19

Remove the MCU box security strap by removing the (2) 1/4" tamper-resistant screws with a 5/32" pin-in-hex security bit (included). Route the long cable from the door to the MCU via the side cable guard and the flexible conduit into the MCU box. Connect the cable to the MCU plug labeled "CAN 1." Zip-ties should be used along the cable guard with the provided slots to hold the cables out of the way. Trim zip-tie tails.

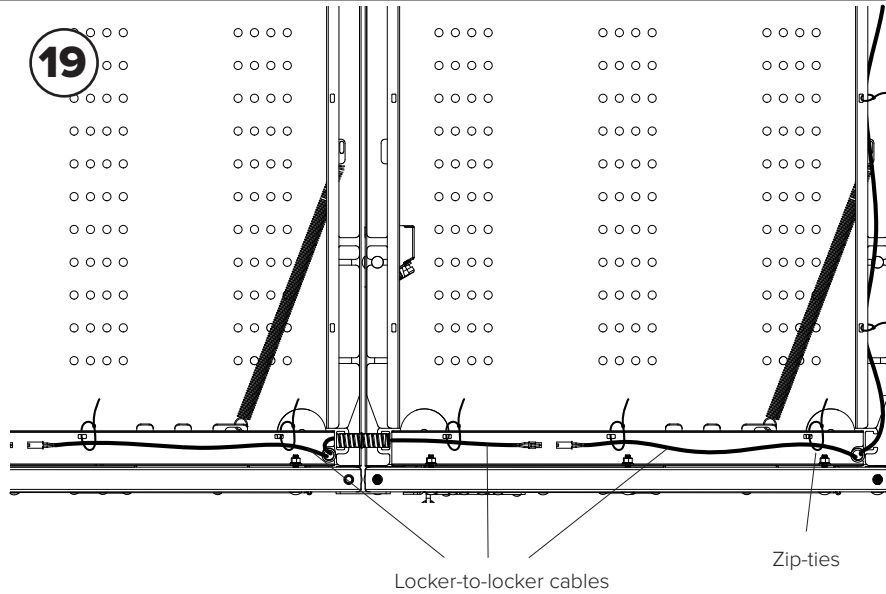

MCU Cable

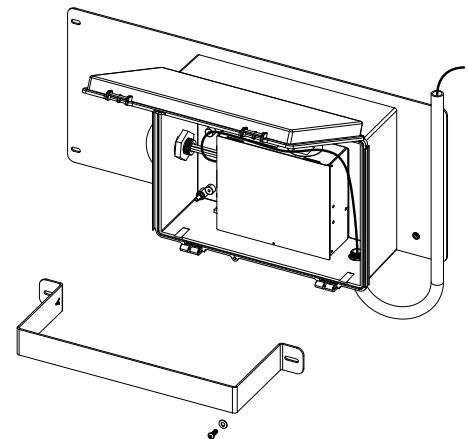

20

Run the locker-to-locker cable from the next locker through the short length of conduit and connect it to the cable from the previous locker. Repeat this for the remaining locker cables.

21

Connect the MCU to the included power supply and the power supply to 120V power. Turn the MCU on with the toggle switch, wait a few minutes, and test each locker to confirm Bikeep functions. Test each door with the mechanical key to confirm the mechanical override functions.

22

If the lockers include e-bike charging, a licensed electrician will install the receptacle and timer.

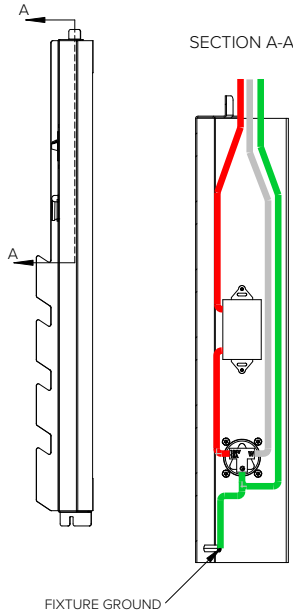

ALL ELECTRICAL WIRING TO BE PERFORMED BY A LICENSED ELECTRICIAN IN ACCORDANCE WITH NEC OR THE LOCAL CODE

ALL WIRES AND CONDUIT SUPPLIED BY INSTALLER

1. ROUTE ELECTRICAL WIRES THROUGH THE LOCKER FIXTURE.
2. FASTEN THE ELECTRICAL TIMER TO THE FIXTURE WITH (2) SCREWS.
3. ROUTE THE POSITIVE WIRE THROUGH THE TIMER AND THEN TO THE RECEPTACLE.
4. CONNECT ELECTRICAL WIRES TO THE RECEPTACLE.
5. FASTEN THE RECEPTACLE AND GASKET TO THE FIXTURE WITH (4) SCREWS AND NUTS.
6. ATTACH THE GROUND WIRE WITH #10 RING LUG TO FIXTURE GROUND WITH A #10-24 SCREW + TOOTH WASHER.
7. CONNECT POWER AND NEUTRAL WIRES TO GCFI CIRCUIT BREAKER 125V/15A MAX.

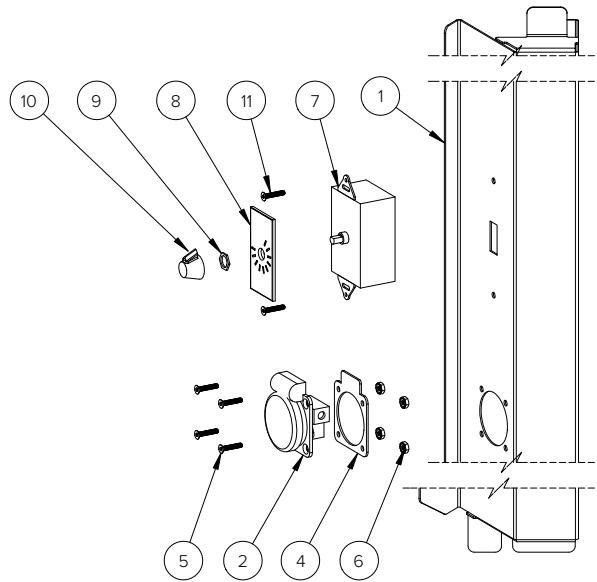

ITEM NO.	PART NUMBER	QTY.
1	LOCKER CHARGING BOX 600112-A	1
2	INTERNATIONAL CONFIGURATIONS 15 Amp, 125 Volt, NEMA 5-15R, Single Receptacle, 70020	1
4	INTERNATIONAL CONFIGURATIONS 15 Amp, 125 Volt, NEMA 5-15R, Single Receptacle, 70020, Gasket	1
5	BOLT 6-32 X .75, FLAT, PIN-IN-TORX	4
6	NUT 6-32, TOOTHED WASHER	4
7	ELECTRICAL TIMER	1
8	ELECTRICAL TIMER FACE PLATE	1
9	ELECTRICAL TIMER NUT	1
10	ELECTRICAL TIMER KNOB	1
11	BOLT 6-32 X .75, FLAT, PIN-IN-TORX	2

23

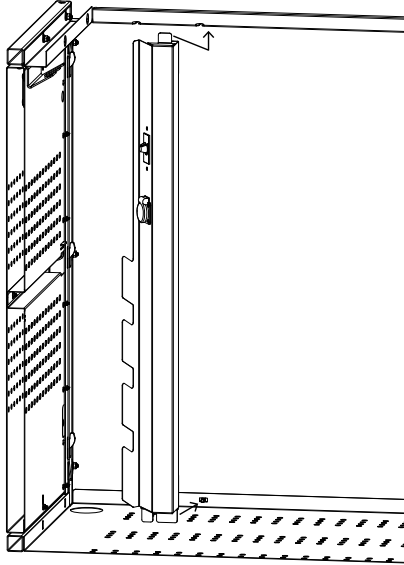

Remove the 5/16" nut and washer at the bottom of the left side panel, nearest the door. Feed the power wires through the slot in the cable guard and fit the tab on the charging fixture into the same slot. Lower the bottom of the charging fixture so the bottom slot meets the 5/16" carriage bolt at the panel bottom. Note the power wires aren't pinch and tighten the 5/16" nut and washer. Zip-ties should be used along the cable guard with the provided slots to hold the wires out of the way. Trim zip-tie tails.

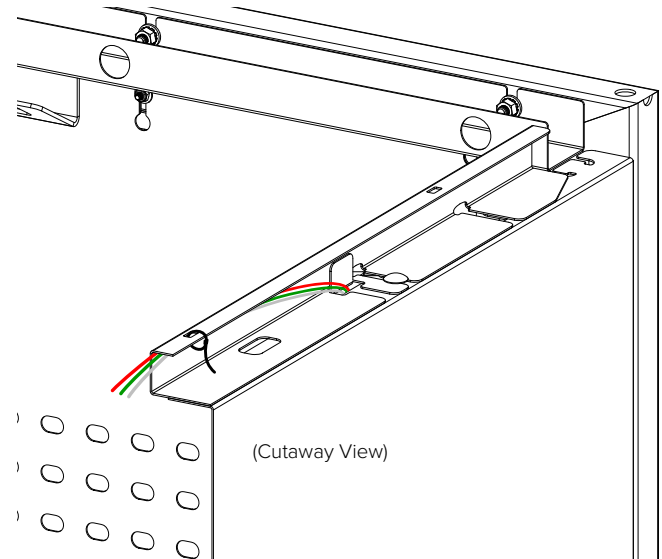
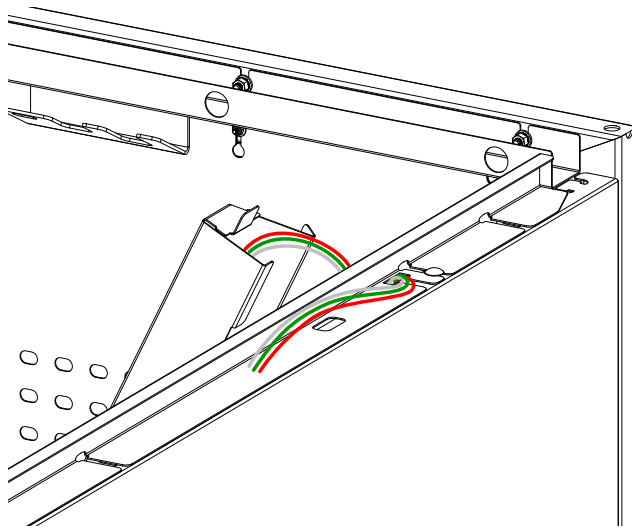

24

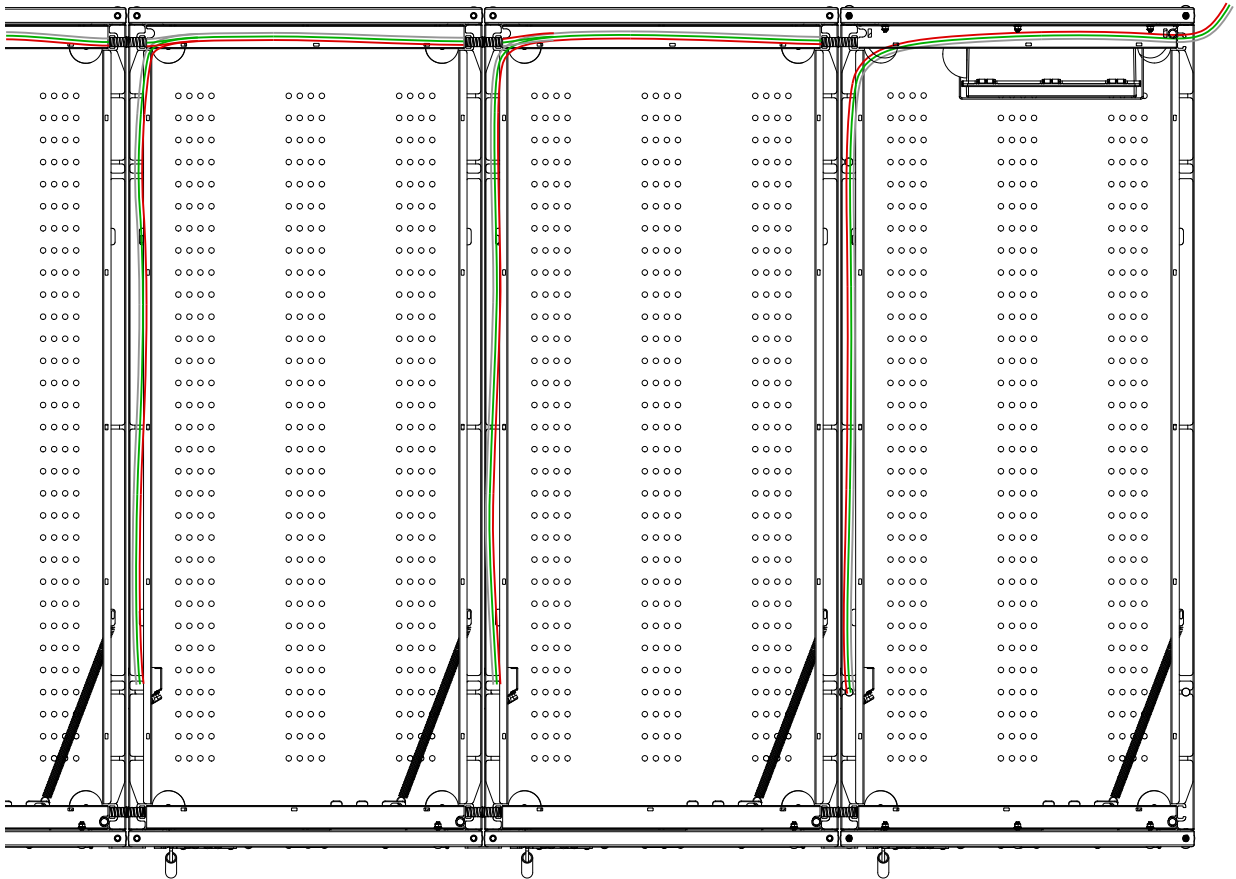

Repeat for remaining e-bike charging outlets and run power wires to the rear of the lockers, through the short flexible conduit, and to the power entry point.

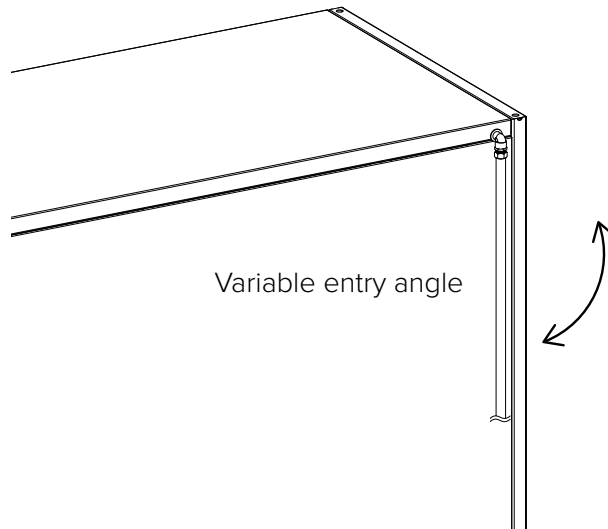

25

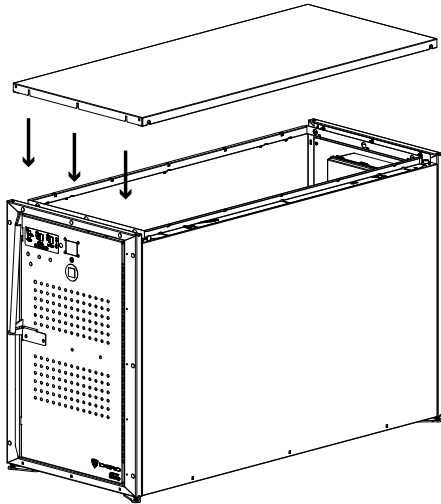

Loosen the (3) 5/16" nuts holding the front cable guard on and lower the roof panel into place. The front flange of the roof panel will fit between the door frame and front cable guard. If flexible conduit between lockers is present, the cutouts in the roof panel will fit over it and hold it captive.

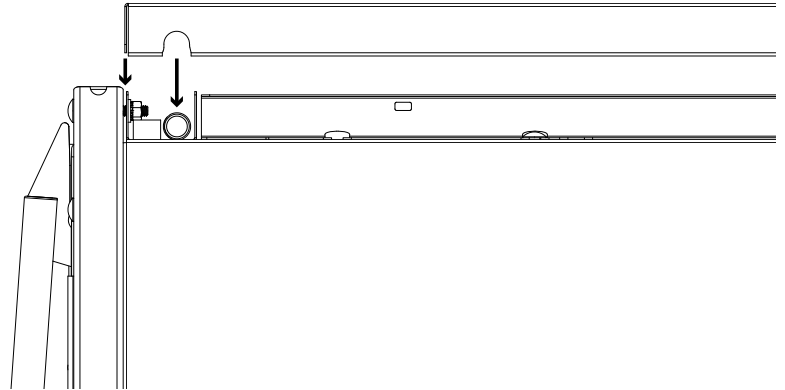

26

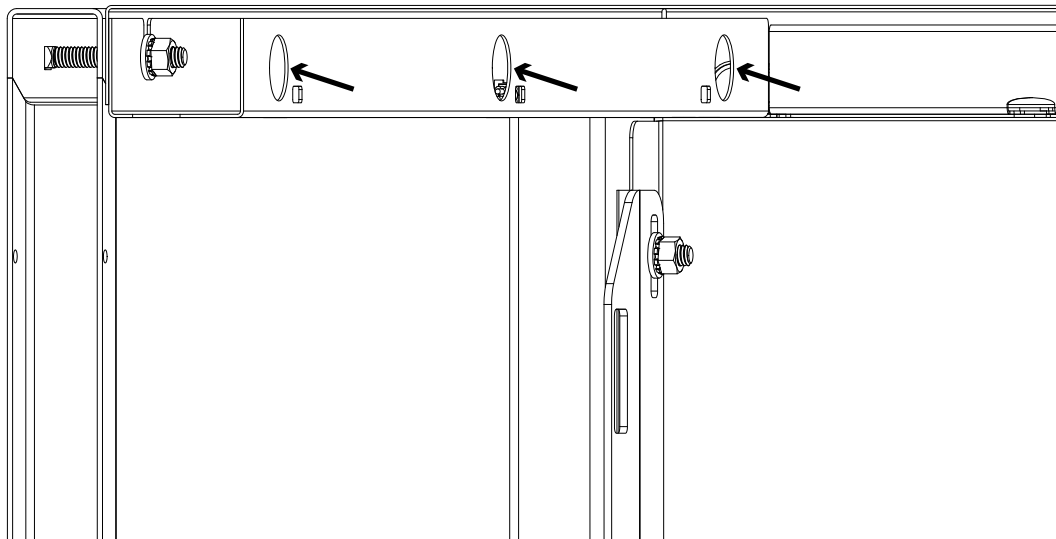

From inside the locker, the (3) 5/16" nuts in front, and (3) in back, can be tightened with a 1/2" extension socket through the holes in the cable guards. Note to be careful of the cables.

27

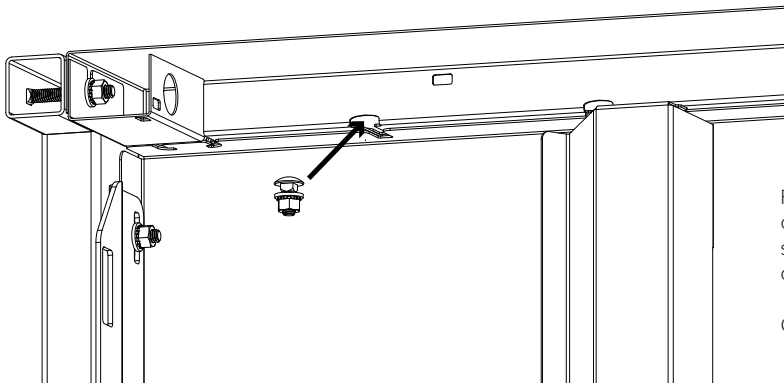

From inside the locker, place (3) assembled 5/16" x 3/4" carriage bolts, washers, and nuts in the slots on each side of the roof panel. Tighten all nuts. Note to be careful of the cables and wires.

Confirm all cables and wires are behind the guards.

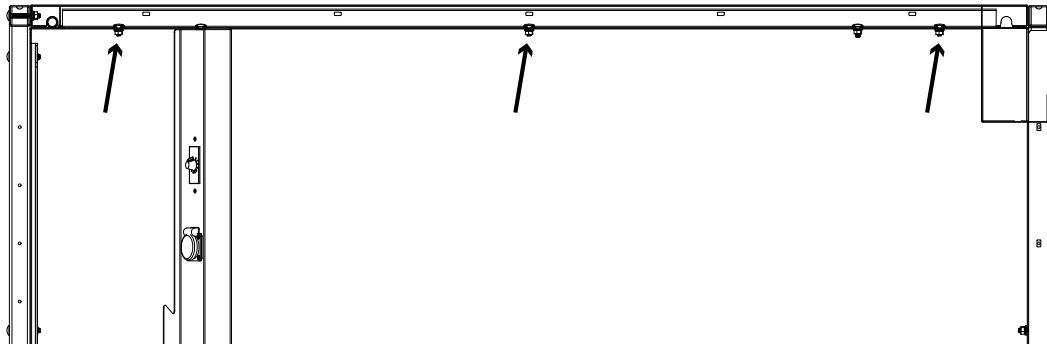

28

Confirm all locker assembly hardware is tight and that door locks operate properly.

5-LOCKER ASSEMBLY

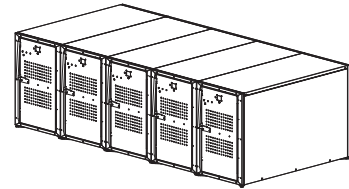
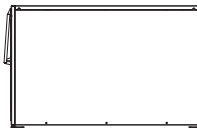
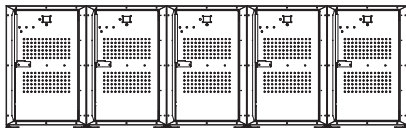

10-LOCKER ASSEMBLY

