

The Ultra Space Saver Squared has several steps for installation. Note that the single and double sided setups and parts are different. Make sure you follow the instructions according to the model you ordered.

### Recommended Base Materials:

Solid concrete is the best base material for installation. Make sure nothing is underneath the base material that could be damaged by drilling (i.e. post-tension cable). Use the 3.75" wedge anchors that are included to install the rack into the concrete (wall anchors are 3").

### Installation:

Sort out the parts to the rack and identify each of them accordingly. The 1" carriage bolts are for assembly of the rack and the 3.75" wedge anchors are for mounting the rack to the floor.

### Single Sided Parts

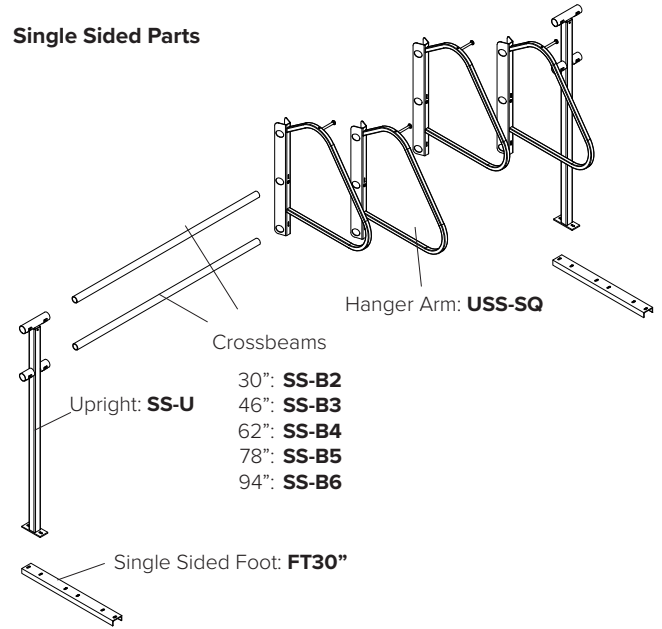

### Double Sided Parts

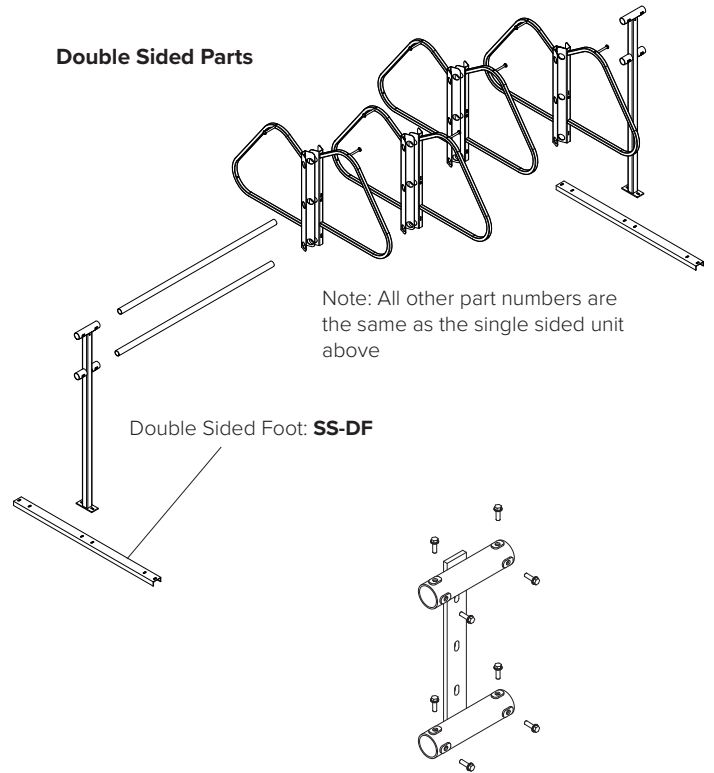

### Reading your Dero designed layout

Ultra Space Saver Squared come in varying configurations, making it **very important** that you carefully follow the layout provided by Dero when installing the racks. If you do not follow the diagram, you may well end up short of parts. The length of each Ultra Space Saver Squared unit is indicated by a number ranging from B2-B7 in the layout. This number corresponds to the length of crossbeams to be installed. In the example provided below the Ultra Space Saver Squared is to be installed starting with two B4 units, which have 62" crossbeams, followed by a B5, which has 78" crossbeams.

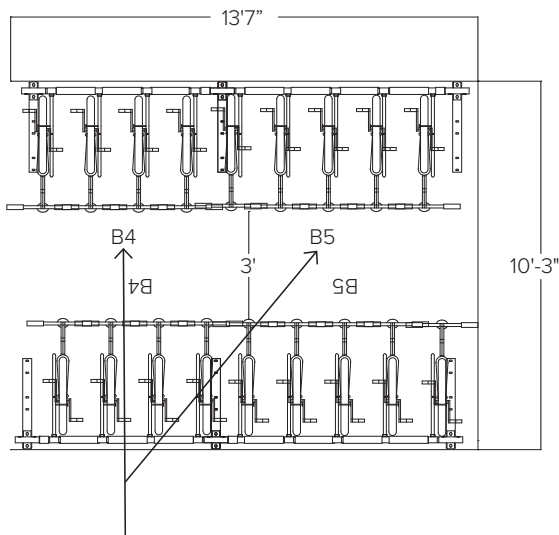

These numbers indicate the number of arms between brackets for each Ultra Space Saver Squared unit to be installed.



**TOOLS NEEDED**

- 9/16" Wrench/Socket
- 3/8" or 1/2" Masonry Drill Bit (Depending on anchor type)
- Tape Measure
- Drill (Hammer drill recommended)
- Hammer
- Level
- Marker or pencil
- Pin-in-hex tool (provided)

**NOTE**

Before installing make sure the wall is strong enough to accommodate the rack fully loaded with bikes. Steel stud walls are not suitable for installation

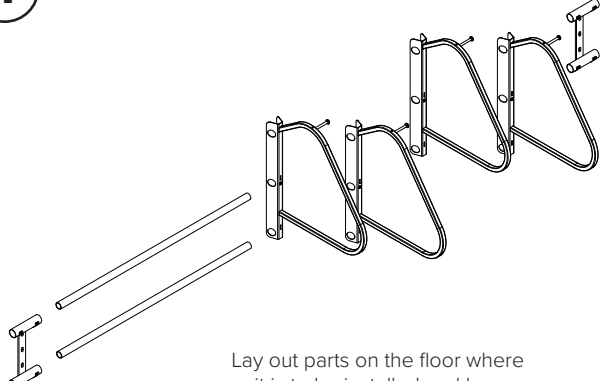
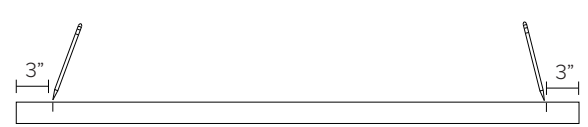
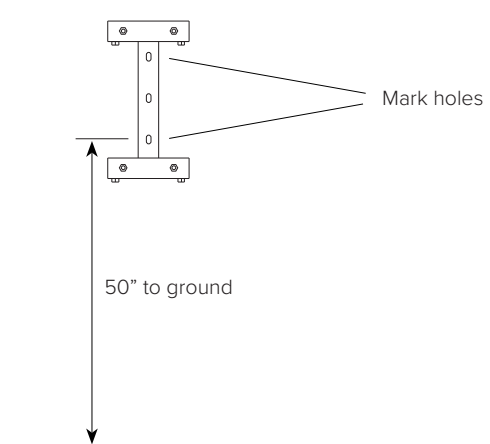
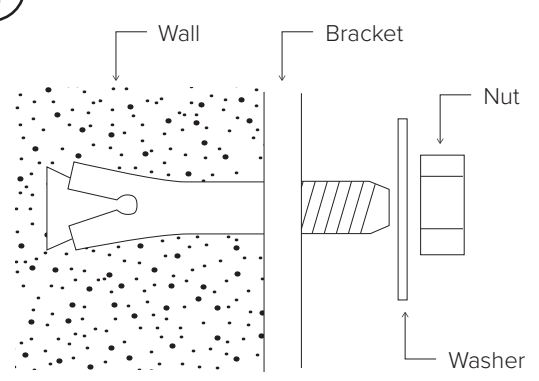
<div style="text-align: center; font-size: 2em; font-weight: bold; border: 1px solid black; border-radius: 50%; width: 40px; height: 40px; margin: 0 auto; display: flex; align-items: center; justify-content: center;">1</div>  <p style="text-align: center;">Lay out parts on the floor where unit is to be installed and be sure you have all necessary parts.</p>	<div style="text-align: center; font-size: 2em; font-weight: bold; border: 1px solid black; border-radius: 50%; width: 40px; height: 40px; margin: 0 auto; display: flex; align-items: center; justify-content: center;">2</div>  <p style="text-align: center;">On crossbeams, Place a mark three inches from each end. This mark will show you how far to slide the crossbeam into the wall bracket.</p>
<div style="text-align: center; font-size: 2em; font-weight: bold; border: 1px solid black; border-radius: 50%; width: 40px; height: 40px; margin: 0 auto; display: flex; align-items: center; justify-content: center;">3</div>  <p style="text-align: center;">Place first wall bracket on wall where you want to install the bike rack. The lowest hole of bracket should be 50" from the ground. Mark holes for drilling.</p>	<div style="text-align: center; font-size: 2em; font-weight: bold; border: 1px solid black; border-radius: 50%; width: 40px; height: 40px; margin: 0 auto; display: flex; align-items: center; justify-content: center;">4</div>  <p style="text-align: center;">Drill Holes into wall, put the wall bracket back up and insert wall anchors through holes in bracket and set the anchors. For setting the anchors and diameter and depth of holes, follow instructions sent with the anchors. Make sure bracket is level.</p>

**5**

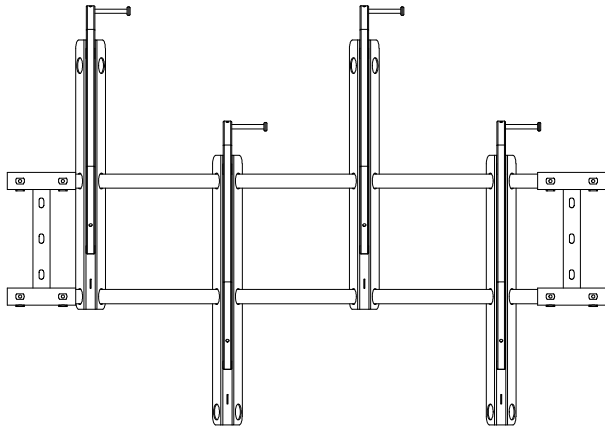

Stagger height of arms

Thread 3/8" by 3/4" tightening bolts into holes in bracket. Insert crossbeams into bracket. Slide on arms and make sure arms are staggered. Use provided security tool to secure the arms with the set screws 16" apart on-center. Install end bracket, making sure crossbeams are level.

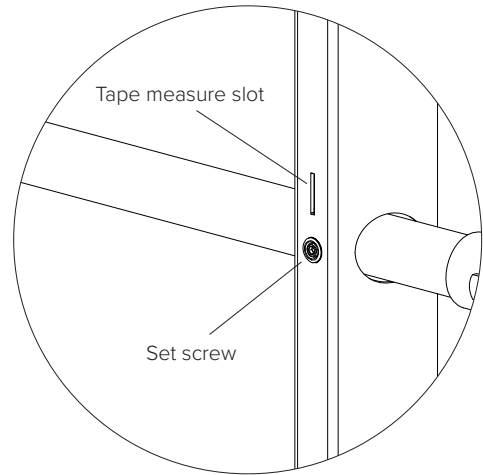

**6**

If installing more than one set of Ultra Space Saver Squared arms, continue from last installed wall bracket and repeat steps 3-5 above.

**Optional Wheelstop**

For the optional wall-mounted wheelstop, anchor the unit to the wall so that the center of the wheelstop bracket is 23" below the center of the bottom slot of the crossbeam bracket.

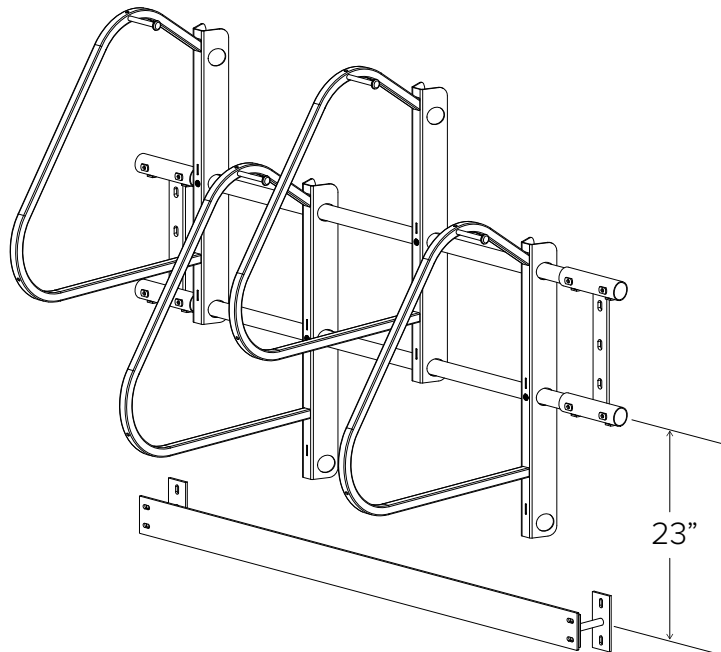

**TOOLS NEEDED**

9/16" Wrench/Socket  
3/8" Masonry Drill Bit  
Tape Measure  
Drill (Hammer drill recommended)  
Hammer

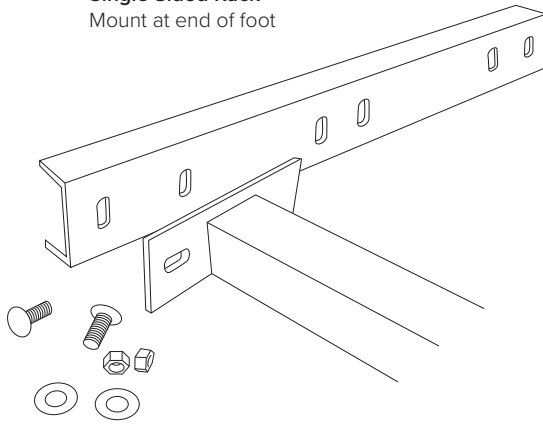
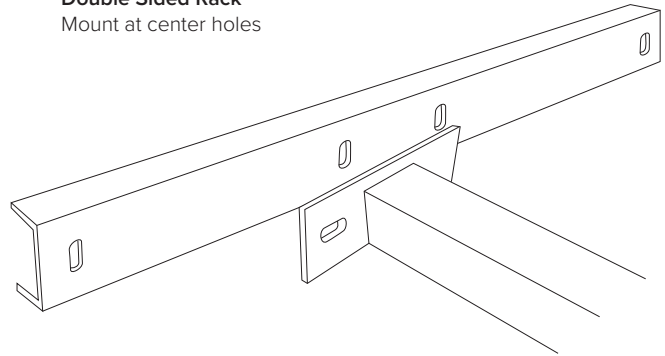
**1****Single Sided Rack**  
Mount at end of foot**Double Sided Rack**  
Mount at center holes

Measure out space. Attach feet to uprights with carriage bolts provided.

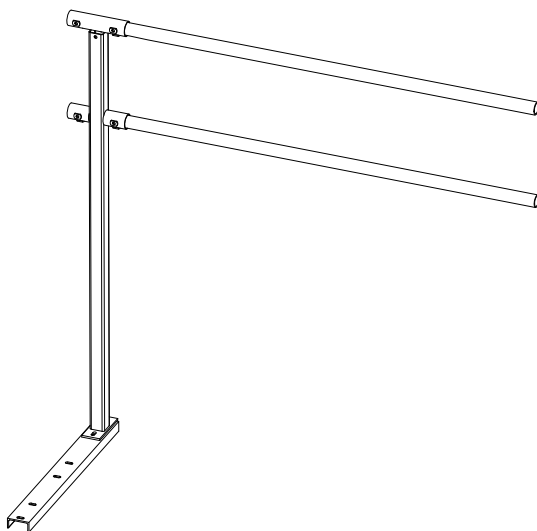
**2**

Place crossbeams into brackets. Finger-tighten bolts to hold crossbeams loosely in place.

**3**

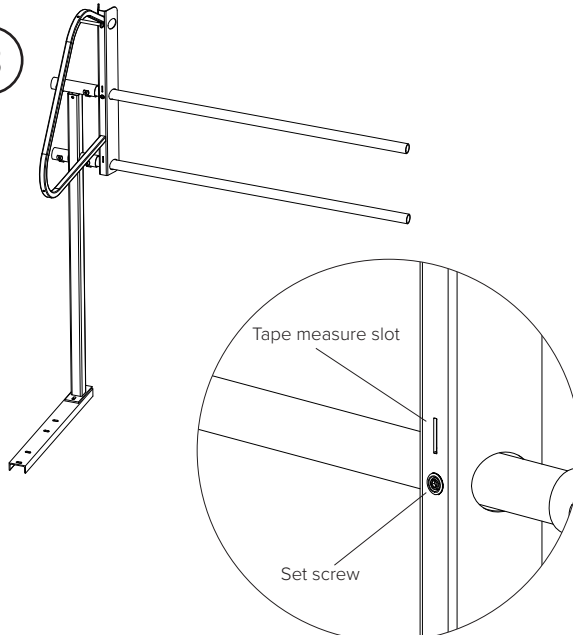

Carefully slide first hanger arm onto crossbeams. For single-sided racks leave a 3" space between the hanger arm and mounting bracket. Use the provided security tool to tighten set screw to hold hanger arm in place.

**4**

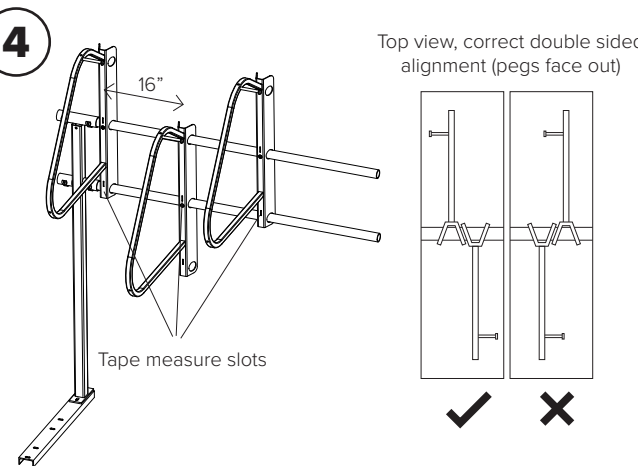

Top view, correct double sided alignment (pegs face out)

Gently slide on remaining arms making sure to stagger height of each arm and tighten each set screw. Standard spacing between arms is 16". For double sided model slide arms on opposite each other. Repeat until the crossbeams are full.

**To avoid bicycle conflict on double sided units make sure each arm is installed to the right of its paired arm facing the opposite way (see diagram above).**

**5**

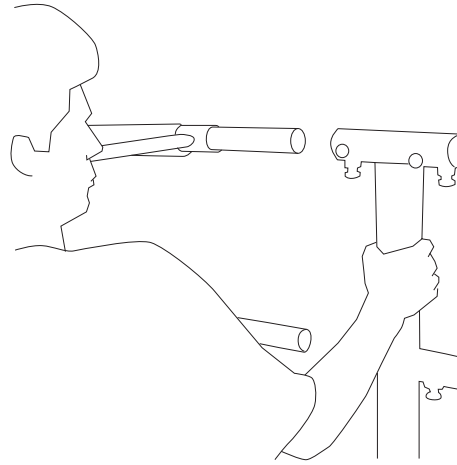

Attach the second upright. Tighten bolts to secure crossbeams in brackets. For add-on units repeat steps.

**6**

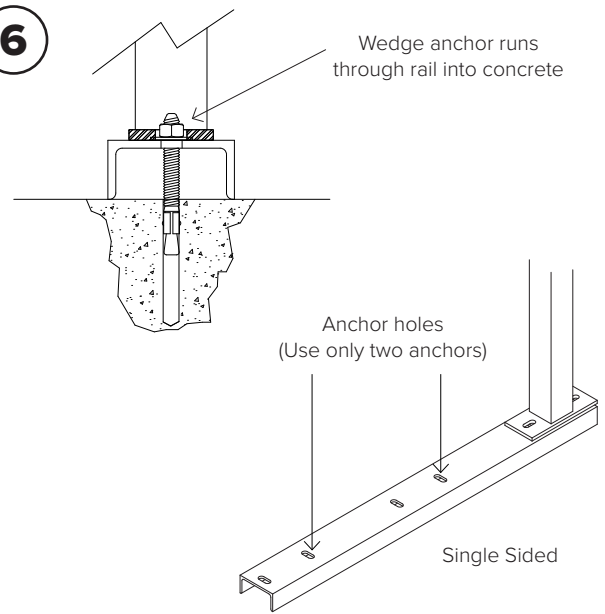

Wedge anchor runs through rail into concrete

Anchor rack to floor with 3.75" wedge anchors.

See diagrams on ensuing page for instructions on installing the optional cane stops.

**1**

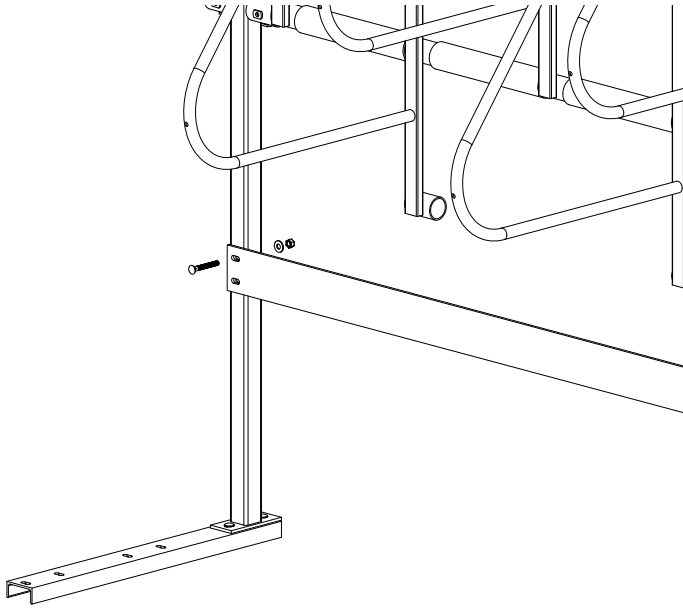

Attach tire stop to uprights with supplied hardware.

**2**

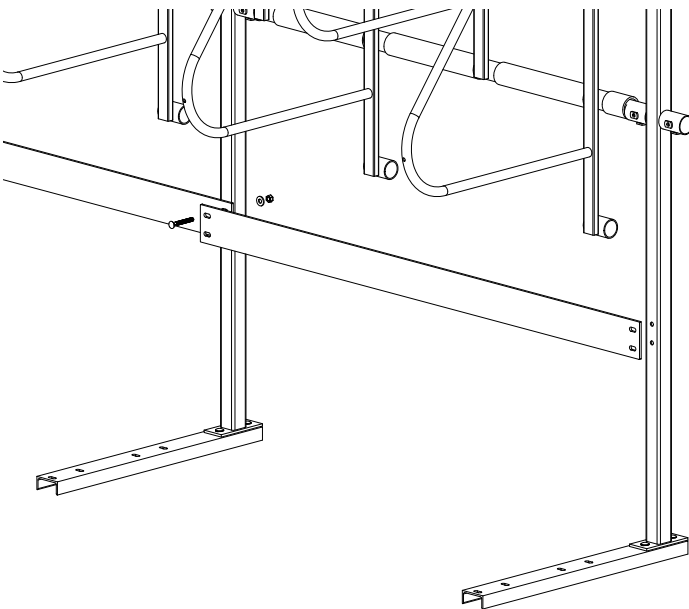

Continue attaching tire stops if using a modular system.

**Instructions for floor mounted racks**

See diagrams below for guidance on installing the optional cane stops onto floor mounted racks. In a run of multiple sections of racks, the cane stops will overlap at the anchoring points.

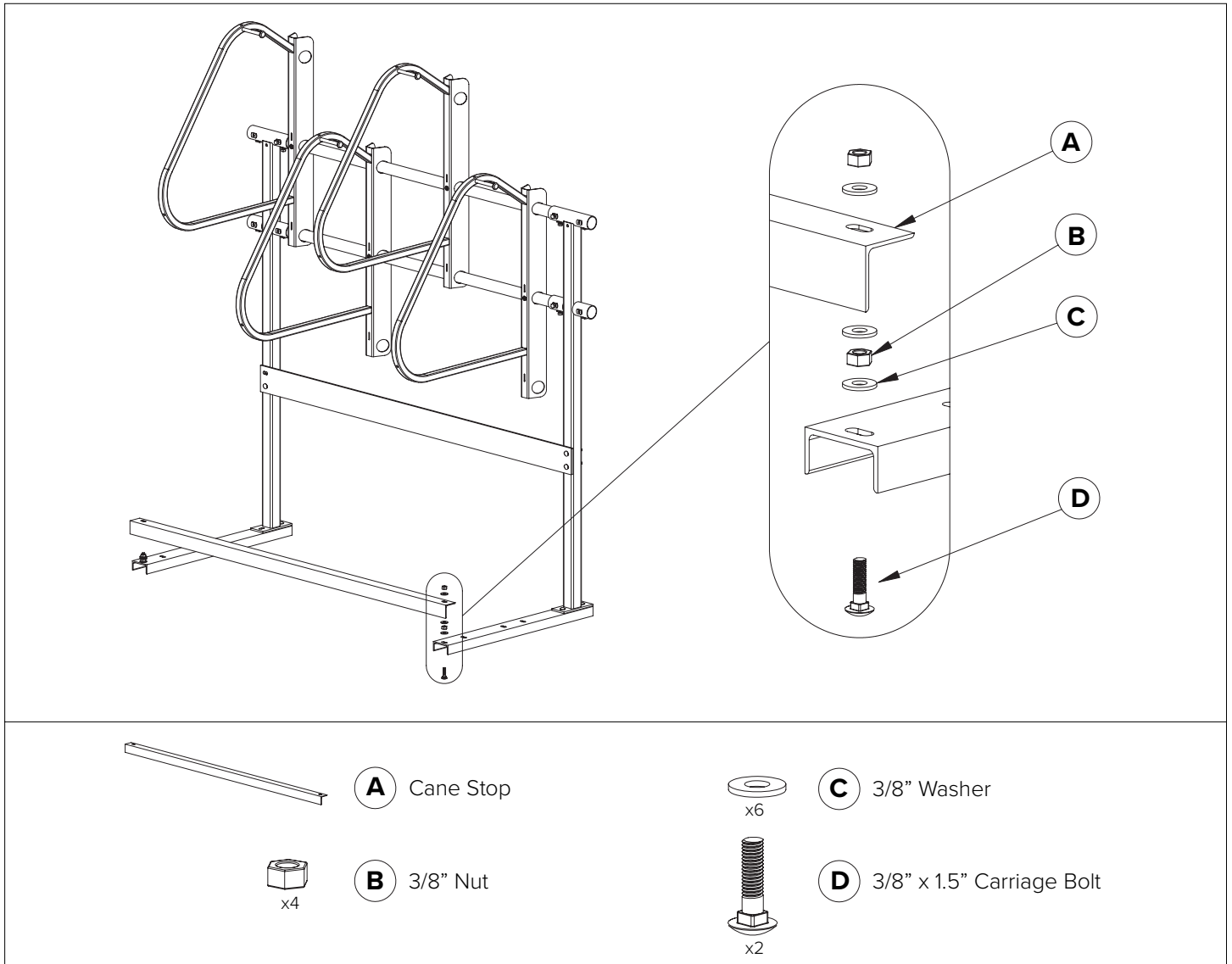



**Instructions for wall mounted racks**

See diagrams below for guidance on installing the optional cane stops onto floor mounted racks. In a run of multiple sections of racks, the cane stops will overlap at the anchoring points.

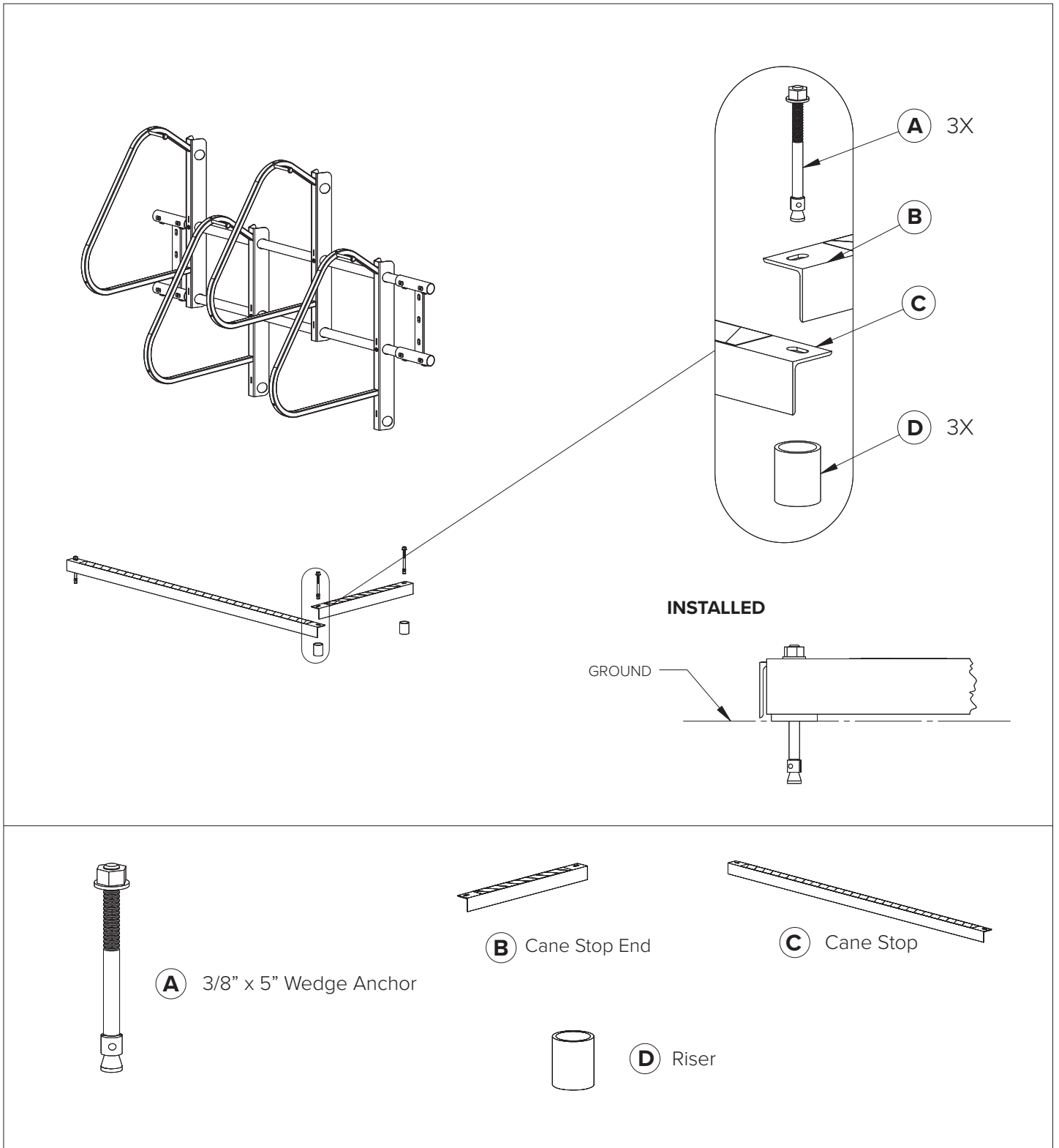

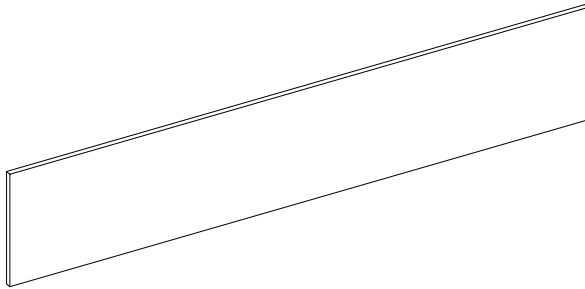
**1**

Use 3/4" x 16" board as a substrate to mount the racks. White Melamine board works well.

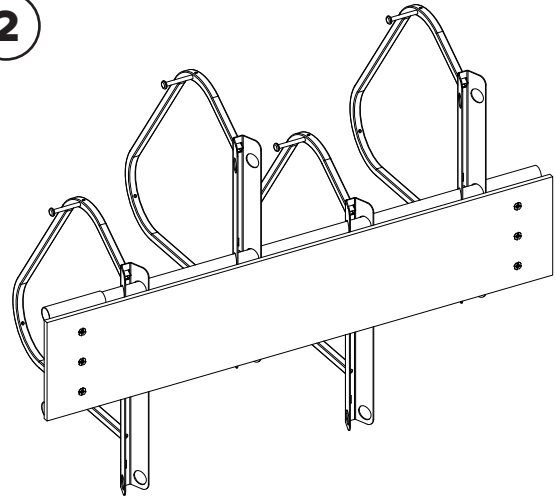
**2**

Lay out the wall mounting brackets on the board and mark the (3) holes per bracket on the board. Drill at marks with a 1/2" drill and press 3/8"-16 Tee Nuts in the back of the board.

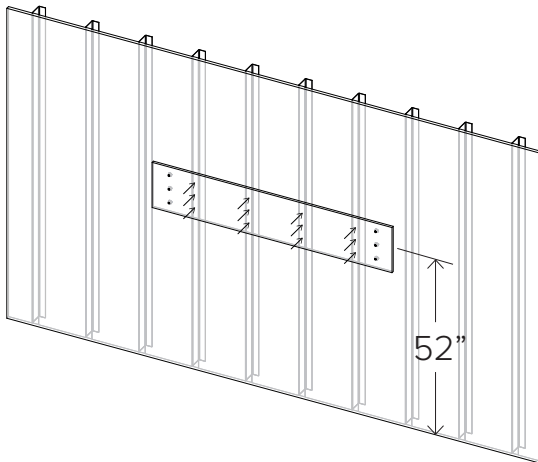
**3**

Place the board on the wall and attach with (3) 3/16" x 3" self-drilling screws at each metal stud. The center of the board should be 52" from the ground. 4" wood screws may be used for wood studs.

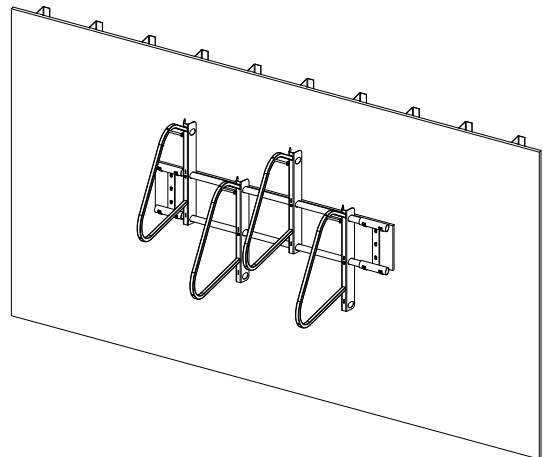
**4**

Attach the USS racks to the board with (3) 3/8"-16 x 1" bolts and washers at each wall mounting bracket.



**Dero is not responsible for verifying installation surface and location. Installer assumes all liability for secure installation.**