

Door Assembly

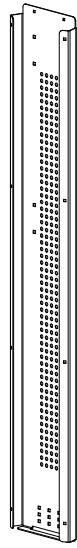

Backbone

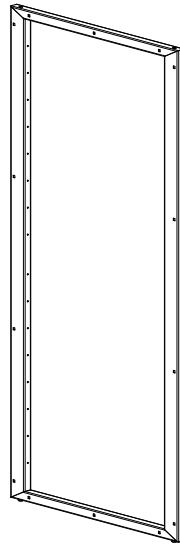

Door Frame

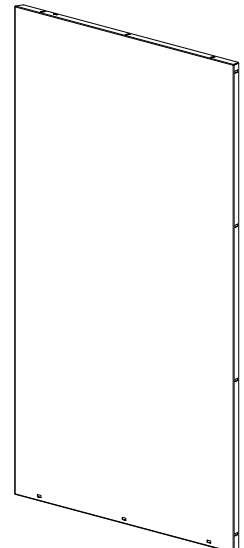

Frame Panel

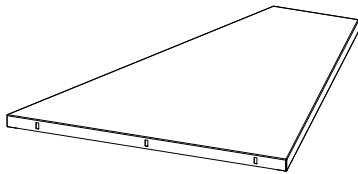

Roof

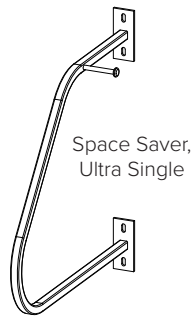

Space Saver,
Ultra Single

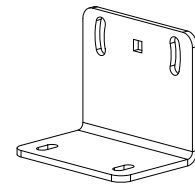

Rear Leveling Foot

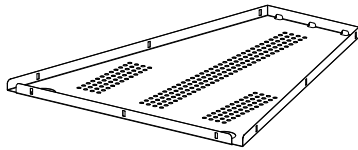

Floor

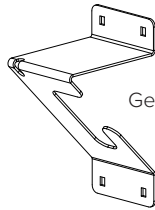

Gear Hook

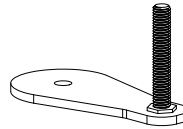

Leveling Foot

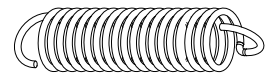

Door Spring

Carriage Bolt .3125 x 2.25

Carriage Bolt .375 x 1.00

Carriage Bolt .3125 x .75

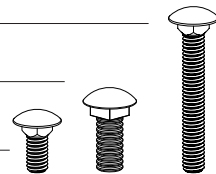

Carriage Bolt 10 x .50

Self Drilling Screw 12-14 X .75



Lock Nut .3125



Lock Nut .375



Lock Nut 10



Washer .3125



Washer .375



TOOLS NEEDED

Hammer	Socket wrench
Bubble level	3/8", 7/16", 1/2", 9/16" sockets
Tape measure	Needle-nose pliers
3/8", 7/16", 1/2", 9/16" wrenches	Hammer drill with 3/8" masonry bit
Power drill	
#3 Philips screw driver bit	

RECOMMENDED BASE MATERIAL

Solid concrete is the best base material for installation. To ensure the proper anchors are shipped with your rack, ask your Dero representative which anchor is appropriate for your application. Be sure nothing is underneath the base material that could be damaged by drilling.

Notify Dero sales department of any ground slope.

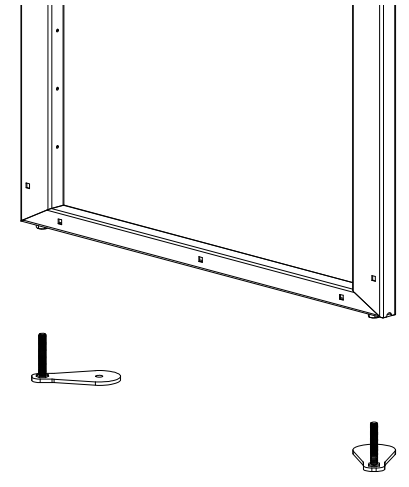
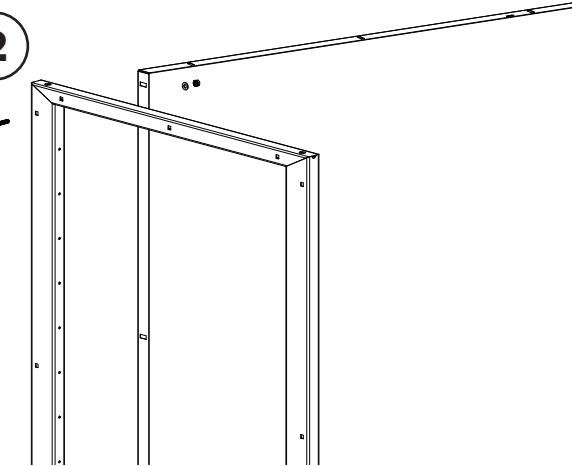
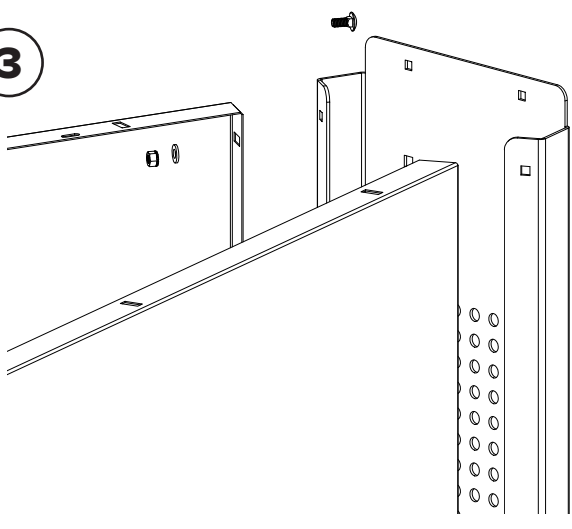
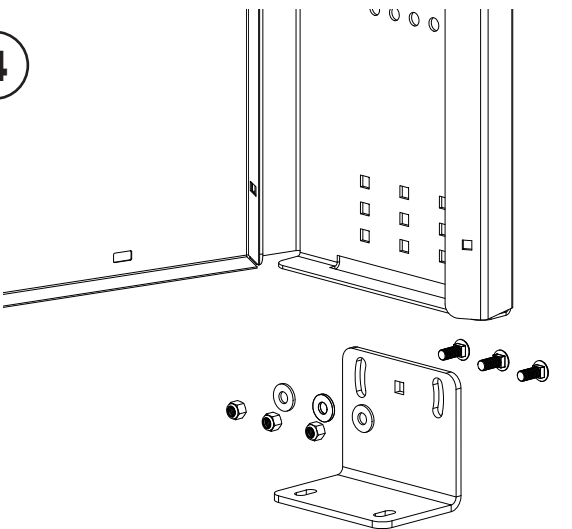
<p>1</p>  <p>Thread the (2) leveling feet into the door frame.</p>	<p>2</p>  <p>Attach (1) frame panel to the door frame with (4) 5/16" x 2.25" carriage bolts, washers, and locknuts. Next add the other frame panel. Leave lock nuts finger-tight.</p>
<p>3</p>  <p>Attach (1) backbone to the frame panels with (8) 5/16" x .75" carriage bolts, washers, and locknuts. Leave lock nuts finger-tight.</p>	<p>4</p>  <p>Attach the rear leveling foot to the backbone with (3) 3/8" x 1.00" carriage bolts, washers, and locknuts. Typically, the top set of holes are used.</p>

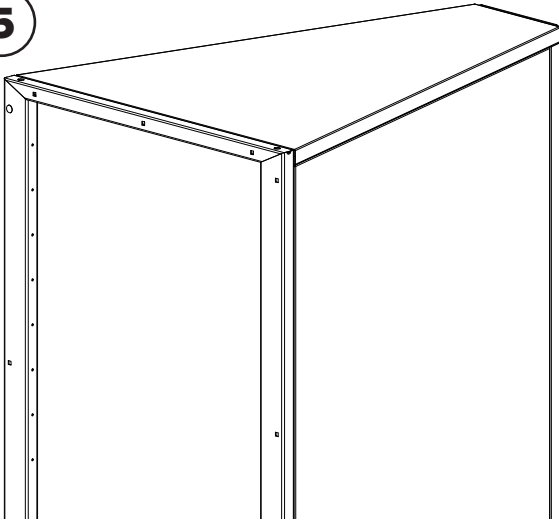
5

Attach the roof panel to the side panels with (6) 5/16" x .75" carriage bolts, washers, and locknuts. Attach the roof panel to the door frame with (3) 5/16" x 2.25" carriage bolts, washers, and locknuts and the backbone with (2) 5/16" x .75" carriage bolts, washers, and locknuts. Leave locknuts finger-tight.

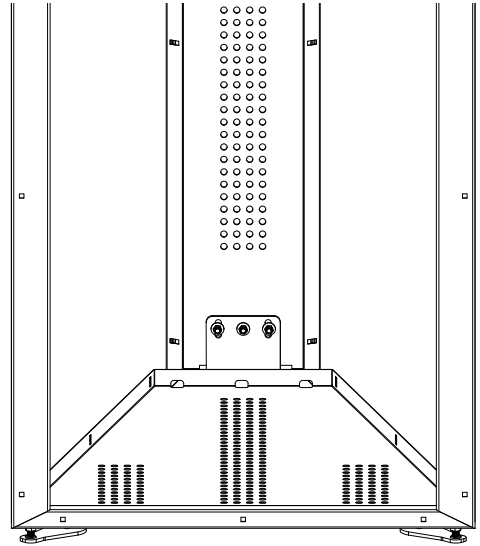
6

Attach the floor panel to the side panels with (6) 5/16" x .75" carriage bolts, washers, and locknuts. Attach the floor panel to the door frame with (3) 5/16" x 2.25" carriage bolts, washers, and locknuts. Leave lock nuts finger-tight.

7

Tighten all locknuts.

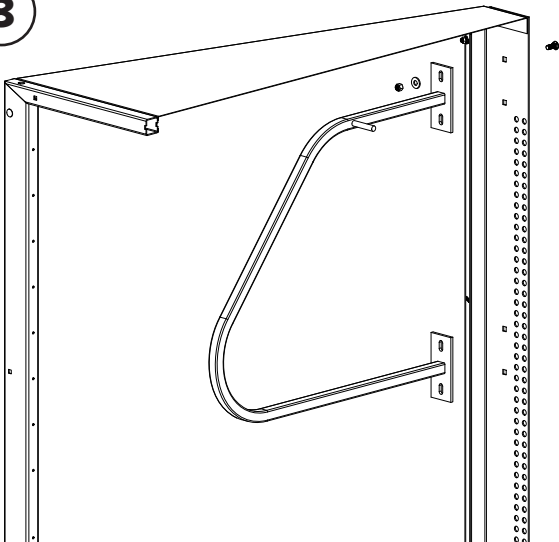
8

Attach the bike rack to the backbone with (4) 3/8" x 1.00" carriage bolts, washers, and locknuts.

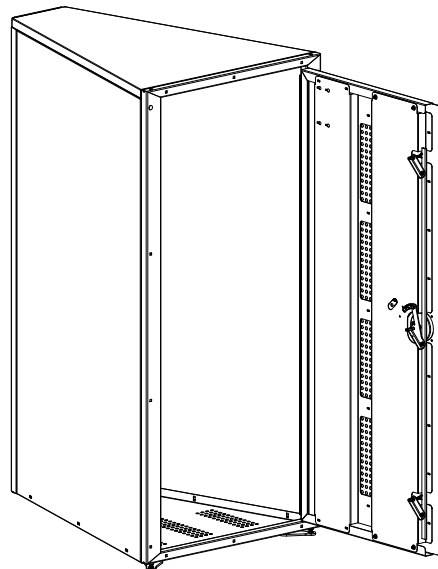
9

Attach the door assembly with (16) #12 x 3/4" self-drilling screws. Pilot holes are present but may be partially filled with zinc.

10

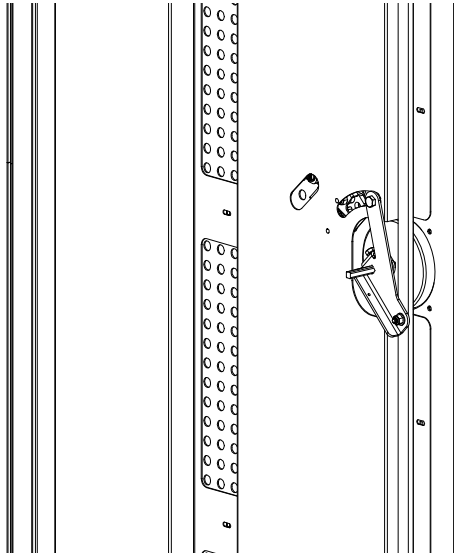

The gap between the door and latch bar may need to be adjusted to properly engage the door frame. This can be done via the 1/4" bolt that tightens against the handle spindle and the 5/16" nuts at the other pivot points.

11

If any twist needs to be taken out of the door, loosen the #10 locknuts, set the door, and re-tighten.

12

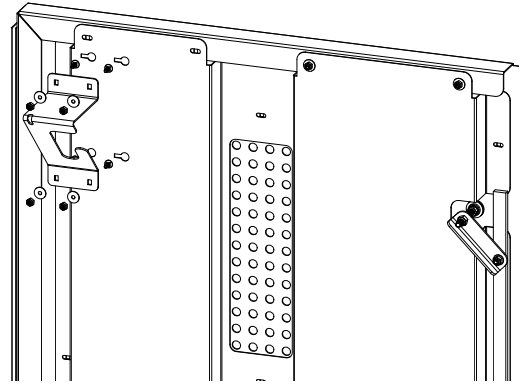

Attach the gear hook to the door back with (4) #10 x .50" carriage bolts, washers, and locknuts.

13

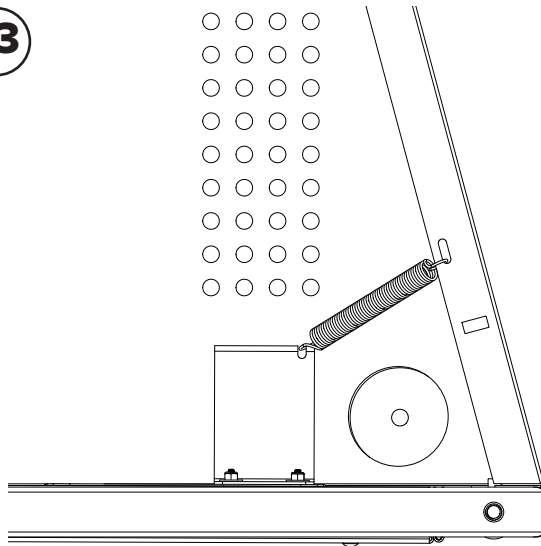

To install the door closer, attach the spring to the gear hook and to the side panel. A needle-nose pliers is helpful.

14

Move the locker into the desired location, level it with the leveling feet, and secure it to the ground with (4) anchors. The front leveling feet anchor holes should line up with the large holes in the locker floor.