



DERO
A PLAYCORE Company



 E-bike charging available!



Smart Bike Parking Stations

by **bikeep**

Bikeep's smart bike parking stations provide the most advanced, high-security network of parking for private bikes. The stations can be operated via smartphone app or swipe card and boast multiple layers of security to keep bikes safe. Charging docks contain a self-locking compartment with an outlet to securely charge an e-bike.

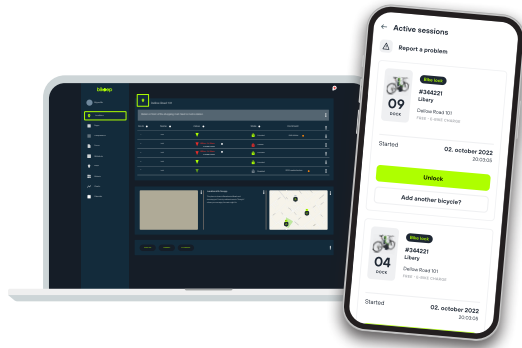

Powerful apps for end-users and admins

Bikeeep's mobile app enables users to interact with the parking network throughout the city. End-users can **plan their commutes** ahead of time, access the parking stations at their destination and **get fast support** if needed.

Bikeeep's Console gathers real-time and **statistical information** about locations, parking usage, and cyclists. It allows system operators to **remotely manage access**, including lock/unlock, payment options, and surveillance.



Multi-Layer security

Bikeeep offers the highest level of security for bikes. The steel locking arm **secures the front wheel and frame** of the bike, and any attempts to cut through the rack will trigger an **audible alarm**. The station also provides automatic **distress signal forwarding** and a **live usage overview**. An optional security camera add on can provide images of each station through the Bikeeep Console.

Optional charging for e-bikes

Bikeeep stations are ready to **fuel the e-bike revolution** with the addition of a lockable compartment to protect bike chargers and to safely top up batteries with an internal GFI outlet.



110VAC power to the location should be handled by a qualified electrician in accordance with local standards and regulations.

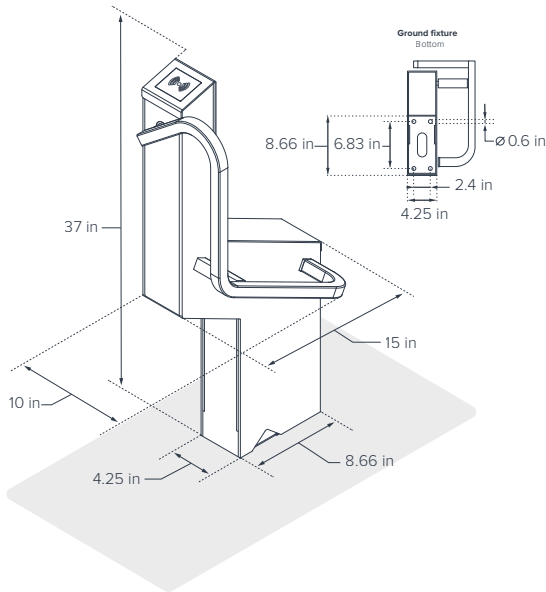

Note: Each Bikekeep station requires an SLA to be renewed annually.

- CAPACITY**
- 5 Bikes
 - 10 Bikes

FINISHES **Powder Coat Only**
A TGIC powdercoat finish is standard. Body of rack is dark gray (RAL 5008) with light green (RAL 6018) arm.

MOUNT OPTIONS

- Surface Mount**
Each dock is mounted directly to concrete surface with steel channel running between stations to cover wiring.

- Ground Plate**
Each dock is mounted to a segment of steel plate.

All installations must be hardwired.

E-BIKE CHARGING

- Non-Charging (No Outlets)**
Requires electrical hookup to a dock at either end of the station.

- Add Outlets for E-Bikes**
Stations for e-bike charging will include an electrical cabinet at one end of each row of docks.

Both charging and non-charging installations require 110v power.

CAMERA

- Optional Security Camera**
Motion-captured security images accessible remotely. Captured video available upon request or by accessing the SD card.
(1 camera per set of docks).

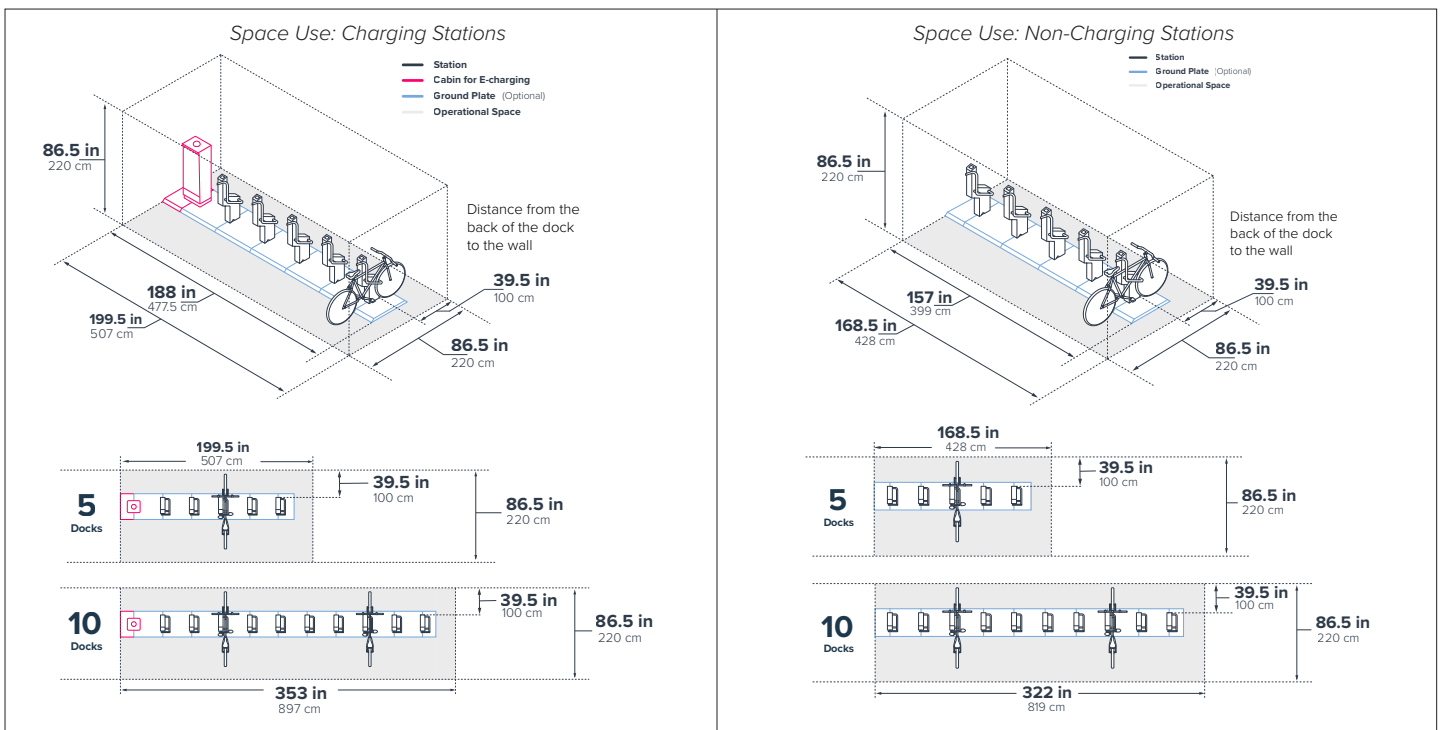

Site Requirements and Installation Overview :: Charging

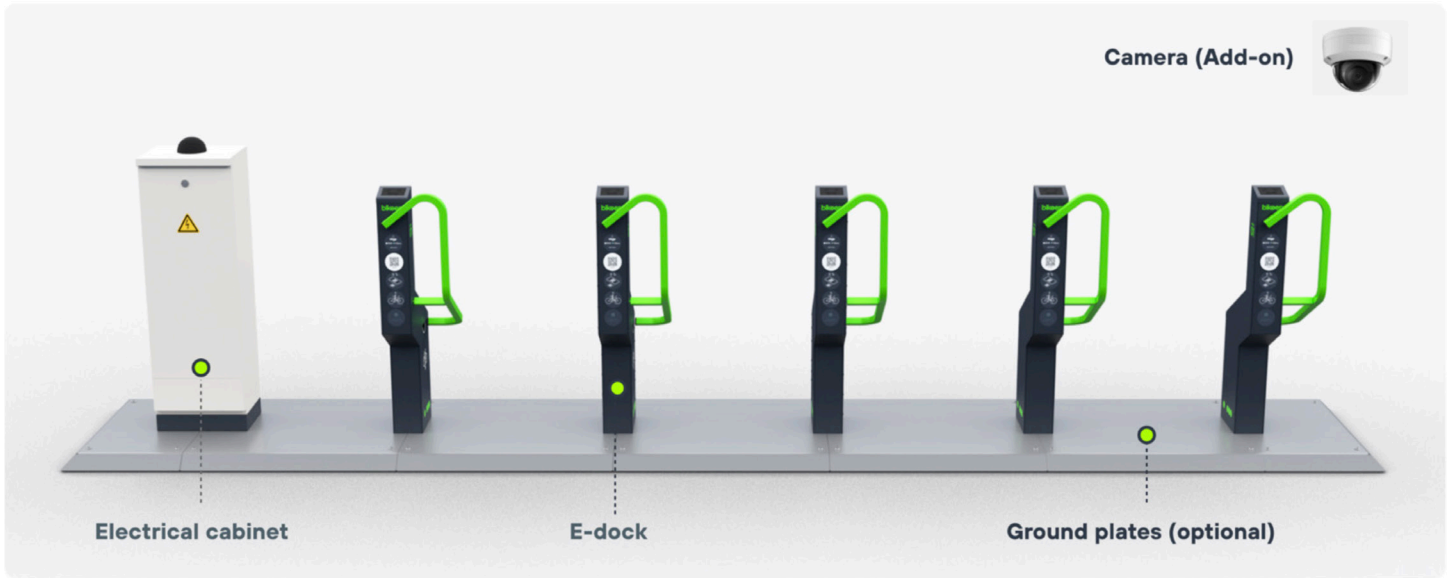

SITE SELECTION AND VALIDATION

When choosing a location for bike parking Stations, consider the following:

- **Visibility:** Place Bikeep Stations in highly visible locations, such as next to main entrances, to attract attention.
- **Weather protection:** Cyclists' prefer their bicycles not to be exposed to extreme weather conditions.
- **Accessibility:** Ensure easy access to the electrical supply and stay within 165 feet of key destinations.
- **Convenience:** Do not obstruct pedestrian paths and avoid stairwells for cyclists.
- **Strategy:** If a building has two or more main entrances on opposite sides, provide a Station at each doorway.
- **Connectivity:** A 4G mobile internet connection must be available at the Station site to provide real-time data on locations, parking usage, and cyclists.
- **Electricity:** 110VAC power to the location should be handled by a qualified electrician in accordance with local standards and regulations.

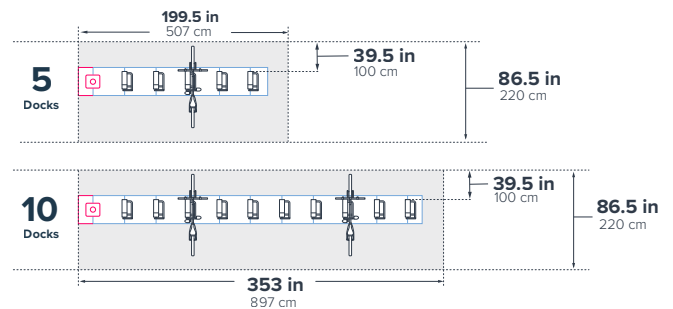
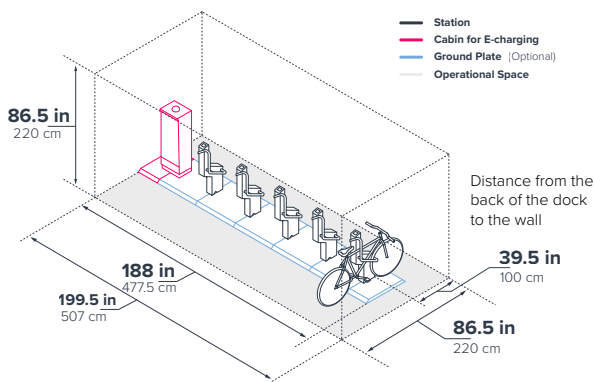

The need for Operational Space is not affected by whether the installation will be with or without Bikeep Ground Plates.

GROUND REQUIREMENTS

Bikeep Stations have been designed to be installable both indoors and outdoors.

They can be installed on any hard surface by one of the three following options:

- **Type 1:** Using **Bikeep ground plates**
- **Type 2:** Making use of a **preexisting concrete** surface with a thickness of at least 4 inches
- **Type 3:** Pouring a **new concrete** surface

Stations cannot be installed on dirt, grass, sand, or similar surfaces. The ground must be solid, flat, and have an incline of no more than 2 degrees.

The installation process for a **5-Dock Station** typically takes **4-6 hours**, while a **10-Dock Station** requires approximately **6-8 hours**. However, if **concrete work** is necessary, the installation duration may extend to **2 days**, as the concrete needs time to harden.



Do not install the docks on slopes where the incline exceeds 2 degrees

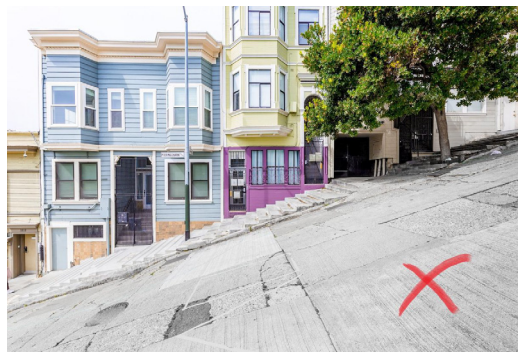

Docks bolted to an existing hard surface (Type 1)



Requirement: Concrete pavement thickness at least 4 inches and not cracked

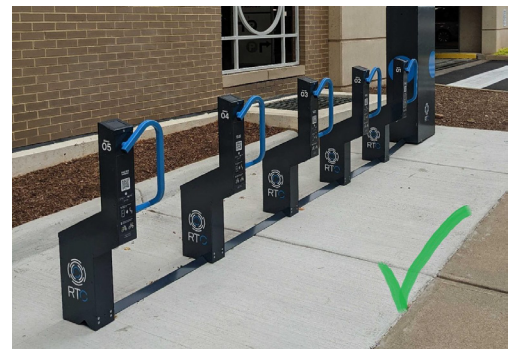

Docks bolted to the ground with a new concrete surface creation (Type 2)

 Requirement: Ground removable for concrete base creation (asphalt, cobblestone, dirt, etc)



Ground plates installation (Type 3)

 Requirement: Ground must be solid and flat. Cannot be installed on dirt, grass, sand, or similar surfaces.

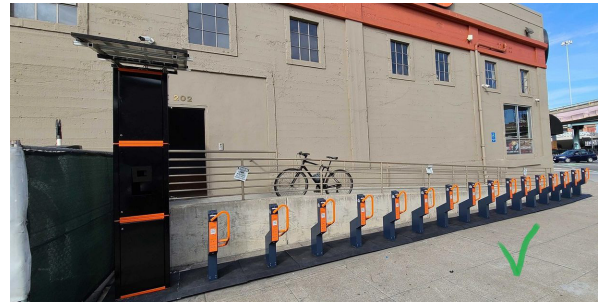

SITE PREPARATION

Incoming line power location

- It is necessary to install the electrical cable at the location in such a way that it has at least a 40" spare, allowing for an electrical connection in the electrical cabinet.
- Bikeep provides all parts for Station assembly. Clients need only to supply electricity for the Station.
- The primary requirement is to deliver power to the electrical cabinet.
- The electrical cabinet is the sole component connected directly to the grid power, as it supplies power to the Bikeep Docks.



E-charging

Each e-dock has a socket outlet pre-assembled in the charging box. **Dock-to-dock** AC charging/power cables are connected in series. One circuit line is up to 5 docks.

Input voltage: **110VAC**

# of Bikeep Smart Docks	Power consumption	Power requirement for e-charging station
5-dock e-charging station	Peak: 2.2kW Typical: .75kW	20A @110VAC
10-dock e-charging station	Peak: 4.4kW Typical: 1.5kW	40A @110VAC (2 circuits, 20A each)

*Calculations are based on 4 amp chargers that are charging at full load.
The actual power consumption may differ.*

STATION ASSEMBLY

The recommended workforce for the installations is 2 people. Please note: The heaviest part of the station is the Smart Dock **main frame**, which weighs about 38 lbs. If the station comes with the ground plate, then the heaviest sub-assembly is the Ground Plate which weighs about 66 lbs.



Overview of the installation process

The Bikeep station's installation process is simplified into 7 steps:

1. Prepare the ground fixers, electrical cabinet, and dock-to-dock cables.
2. Install ground fixers and electrical cabinet. Then run dock-to-dock cables and charging cables underneath the cable channels or inside ground plates.
3. Install a pre-assembled charging box for the ground fixers.
4. Connect power cables to the e-dock socket box.
5. Place the dock body over the charging box and mount it with the bolts included.
6. Tighten all the bolts and connect the dock to the dock cables.
7. Connect all the cables and fix the dock cover to the dock.

Installation types + Standard installation times

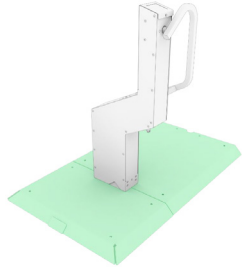
Expected installation times calculated with 2 people on the site.

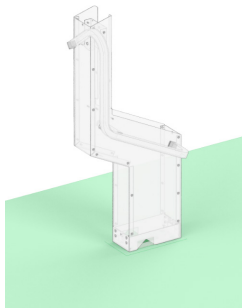
Installation type		Installation time for a 5- Dock Station	Installation time for a 10- Dock Station
<p>Type 1</p> <p>Bikeep Ground Plates</p> <p>Installation using Bikeep Ground Plates.</p>		4 hrs	6 hrs
<p>Type 2</p> <p>New concrete surface</p> <p>Every dock is independently bolted to the ground after new concrete has been poured and it has hardened.</p>		6 hrs + concrete hardening	8 hrs + concrete hardening
<p>Type 3</p> <p>Existing surface</p> <p>Every dock is independently bolted to the ground on an existing concrete surface.</p>		4 hrs	6 hrs
<p><i>The installation of Bikeep Stations only requires basic tools. No special or custom tools are needed. The tools needed are, for example, a cordless drill & drill bits, a hammer, a level, construction string, etc.</i></p>			

TESTING AND LAUNCH

The local installation team fills out the final checklist and ensures that the docks are installed correctly with no damage.

Bikeep checks that everything is working properly from the configuration side and validates that the station is ready for launching and bike parking.

Site Requirements and Installation Overview :: Non-Charging

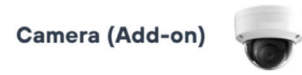

SITE SELECTION AND VALIDATION

When choosing a location for bike parking Stations, consider the following:

- **Visibility:** Place Bikekeep Stations in highly visible locations, such as next to main entrances, to attract attention.
- **Weather protection:** Cyclists' prefer their bicycles not to be exposed to extreme weather conditions.
- **Accessibility:** Ensure easy access to the electrical supply and stay within 165 feet of key destinations.
- **Convenience:** Do not obstruct pedestrian paths and avoid stairwells for cyclists.
- **Strategy:** If a building has two or more main entrances on opposite sides, provide a Station at each doorway.
- **Connectivity:** A 4G mobile internet connection must be available at the Station site to provide real-time data on locations, parking usage, and cyclists.
- **Electricity:** 110VAC power to the location should be handled by a qualified electrician in accordance with local standards and regulations.

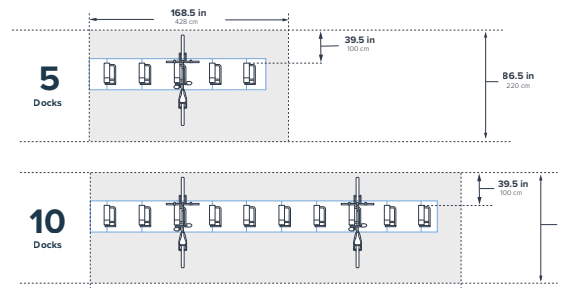
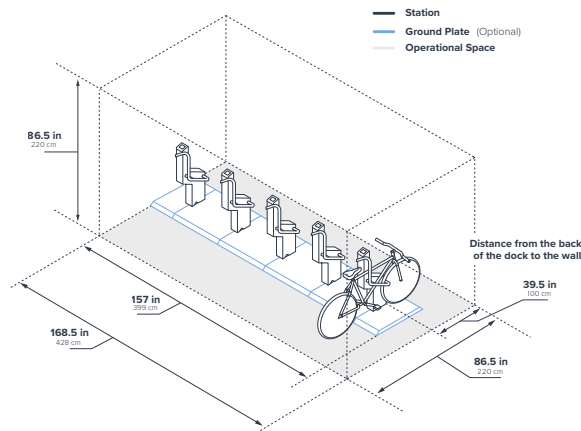

The need for Operational Space is not affected by whether the installation will be with or without Bikekeep Ground Plates.

GROUND REQUIREMENTS

Bikekeep Stations have been designed to be installable both indoors and outdoors.

They can be installed on any hard surface by one of the three following options:

- **Type 1:** Using **Bikekeep ground plates**
- **Type 2:** Making use of a **preexisting concrete** surface with a thickness of at least 4 inches
- **Type 3:** Pouring a **new concrete** surface

Stations cannot be installed on dirt, grass, sand, or similar surfaces. The ground must be solid, flat, and have an incline of no more than 2 degrees.

The installation process for a **5-Dock Station** typically takes **4-6 hours**, while a **10-Dock Station** requires approximately **6-8 hours**. However, if **concrete work** is necessary, the installation duration may extend to **2 days**, as the concrete needs time to harden.



Do not install the docks on slopes where the incline exceeds 2 degrees

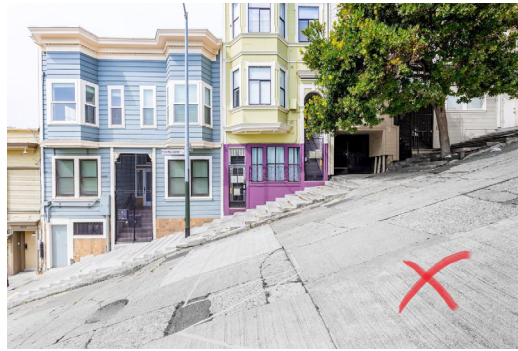

Docks bolted to an existing hard surface (Type 1)



Requirement: Concrete pavement thickness at least 4 inches and not cracked

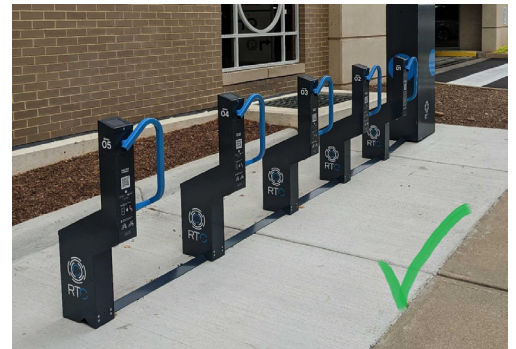

Docks bolted to the ground with a new concrete surface creation (Type 2)

 Requirement: Ground removable for concrete base creation (asphalt, cobblestone, dirt, etc)



Ground plates installation (Type 3)

 Requirement: Ground must be solid and flat. Cannot be installed on dirt, grass, sand, or similar surfaces.

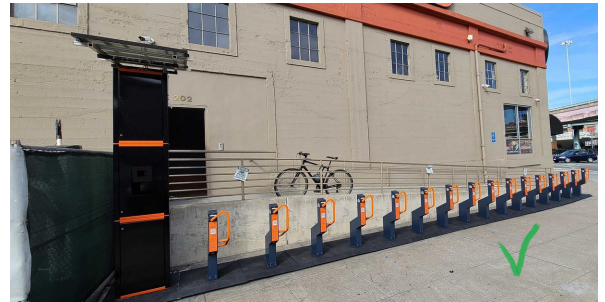

SITE PREPARATION

Incoming line power location

It is necessary to install the electrical cable at the location in such a way that it has at least a 40-inch spare, allowing for an electrical connection in the first dock.

The primary requirement is to deliver power to the first dock.

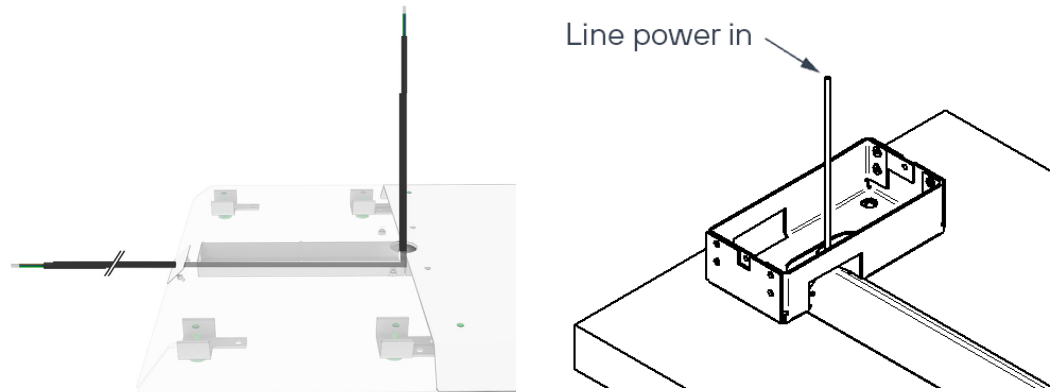

Input voltage: **110VAC**

# of Bikeep Smart Docks	Power consumption	Power requirement
5-dock station	15W	Less than 1A @110VAC
10-dock station	20W	
15-dock station	30W	
20-dock station	35W	

STATION ASSEMBLY

The recommended workforce for the installations is 2 people. Please note: The heaviest part of the station is the Smart Dock **main frame**, which weighs about 38 lbs. If the station comes with the ground plate, then the heaviest sub-assembly is the Ground Plate which weighs about 66 lbs.



Overview of the installation process

The Bikeep station's installation process is simplified into 7 steps:

1. Prepare the ground fixers, electrical cabinet, and dock-to-dock cables.
2. Install ground fixers and electrical cabinet. Then run dock-to-dock cables and charging cables underneath the cable channels or inside ground plates.
3. Install a pre-assembled charging box for the ground fixers.
4. Connect power cables to the e-dock socket box.
5. Place the dock body over the charging box and mount it with the bolts included.
6. Tighten all the bolts and connect the dock to the dock cables.
7. Connect all the cables and fix the dock cover to the dock.

Installation types + Standard installation times

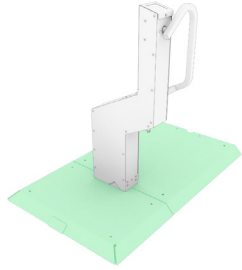
Expected installation times calculated with 2 people on the site.

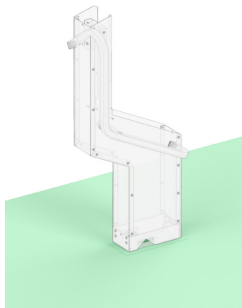
Installation type		Installation time for a 5- Dock Station	Installation time for a 10- Dock Station
<p>Type 1</p> <p>Bikeep Ground Plates</p> <p>Installation using Bikeep Ground Plates.</p>		4 hrs	6 hrs
<p>Type 2</p> <p>New concrete surface</p> <p>Every dock is independently bolted to the ground after new concrete has been poured and it has hardened.</p>		6 hrs + concrete hardening	8 hrs + concrete hardening
<p>Type 3</p> <p>Existing surface</p> <p>Every dock is independently bolted to the ground on an existing concrete surface.</p>		4 hrs	6 hrs
<p><i>The installation of Bikeep Stations only requires basic tools. No special or custom tools are needed. The tools needed are, for example, a cordless drill & drill bits, a hammer, a level, construction string, etc.</i></p>			

TESTING AND LAUNCH

The local installation team fills out the final checklist and ensures that the docks are installed correctly with no damage.

Bikeep checks that everything is working properly from the configuration side and validates that the station is ready for launching and bike parking.

Bikeep Station SLA Comparison

	Standard Station SLA (Station SLA 1)	Premium Station SLA (Station SLA 2)
Monthly cost per station	\$79.00	\$109.00
<i>Internet connectivity¹</i>		
4G SIM card	✓	✓
Additional 4G SIM card for dual redundancy		✓
<i>Parking method</i>		
Bikeep app	✓	✓
Bikeep RFID contactless cards <i>(Must be registered via the Bikeep app prior to usage)</i>	✓	✓
Whitelist access		✓
Online management and monthly parking reports via Bikeep Console	✓	✓
<i>Station access</i>		
Public	✓	✓
Private (phone-based whitelist)		✓
Security camera integration² (1 per station)		✓
<i>Reliability notifications</i>		
Bikeep internal monitoring	✓	✓
External Slack or custom webhook notifications		✓
<i>API</i>		
Real-time parking report API		✓
Whitelisted API		✓

¹ Internet connection signal (4G) must be validated at the station location by the client.

² Camera sold separately

Bikeep Station Maintenance Overview

Maintaining Bikeep Smart Bike Stations is **critical for ensuring** their **optimal functionality and longevity**. Maintenance benefits users by delivering a consistent, high-quality experience and provides long-term advantages to the operators of Bikeep Smart Bike Stations.

It is crucial to have a trained maintenance partner readily available for every installed and operational station. This ensures that any issues can be promptly addressed, maintaining the station's functionality and user satisfaction.

Types of Maintenance

There are two categories of maintenance: Regular Maintenance and On-Demand Maintenance.



REGULAR MAINTENANCE

Regular Maintenance, also known as routine maintenance, is for ensuring a **seamless operation** of Bikeep Smart Bike Stations and Bikeep Docks throughout their entire lifecycle, providing a **reliable service** for end-users.

Regular Maintenance **proactively prevents** critical problems from arising. It can prolong the overall life expectancy of the Bikeep Smart Bike Stations by allowing technicians to routinely inspect vital components or specific subassemblies and identify any **emerging problems**.

For example, if left unattended, functional components of the Bikeep Smart Bike Stations may become defective, thereby **hindering systems** or, in worst-case scenarios, causing **complete failure** and disrupting the station's usability.

Failure to carry out regular maintenance as required will result in the repeal of the station warranty.



ON-DEMAND MAINTENANCE

On-Demand Maintenance addresses **existing problems** where **corrective action** needs to be taken and coordinated by Dero, the manufacturer and service operator. (Please use the customer service contact information below.)

Issues that need On-Demand Maintenance are discovered and reported by Bikeep, clients, or end-users through the Bikeep App or by reaching out to the contact information below. Resolutions are handled on a case-by-case basis.

If an end-user reports damage or issues that render the Bikeep Docks unusable, please use the customer service contact information below. This ensures minimal disruption and maintains the high quality of service expected by users.

Maintenance cycle

Regular Maintenance: The stations must be serviced regularly, according to the usage of the station. Also a correctly completed maintenance record should always be filed.

Regular maintenance intervals should be considered as follows:

- Per dock usage of **1** session per day: **Every 12 months**
- Per dock usage of **1-2** sessions per day: **Every 6 months**
- Per dock usage of **2+** sessions per day: **Every 3 months**

No unauthorized additions or adjustments should be made to the system by a 3rd party.

Estimated time for routine maintenance checkup: 6 minutes per dock

On-Demand Maintenance issues generally arise around once a year. Nevertheless, the need for On-Demand Maintenance maintenance may vary depending on factors like usage rate and the location of the installation.