

Fixit with Air Kit Prime

Fixit with Air Kit 4

Hanger height in upper and lower positions

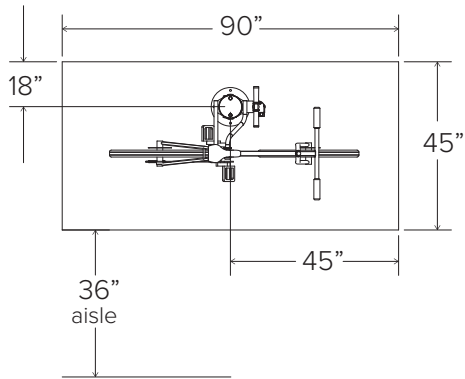

Minimum Footprint

An optional wheel catch is available to hold bikes with no kick stands

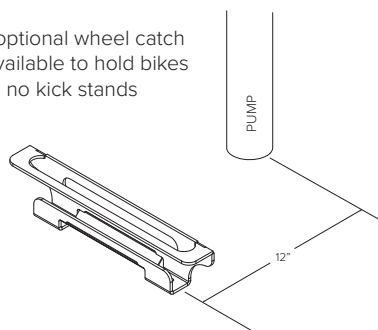

- CAPACITY**
- 1 Bike** (One set of hanger arms)
  - 2 Bikes** (Two sets of hanger arms)

- MATERIALS**
- Main body:** 6" x 12g tube
  - Bike Hanger:** 1" solid round bar
  - Foot:** 10" dia. x .25" plate
  - Tool tethers:** 3/16" stainless steel cable
  - Manual air pump**
  - Hand tools:**
    - Philips and flat head screwdrivers
    - 2.5, 3, 4, 5, 6, 8mm Allen wrenches
    - T25 Torx wrench
    - 32mm Headset wrench
    - 15mm Pedal wrench
    - 8, 9, 10, 11mm box wrenches
    - Tire levers (2)

- FINISHES**
- Galvanized**  
An after fabrication hot dipped galvanized finish is our standard option. **Cap, hanger arms, and strike plates are galvanized only.**
  - Powder Coat**  
Our powder coat finish assures a high level of adhesion and durability by following these steps:
    1. Sandblast
    2. Epoxy primer electrostatically applied
    3. Final thick TGIC polyester powder coat

- MOUNT OPTIONS**
- Surface only**  
Fixit has 10" diameter x.25" foot with four anchors per foot. Tamper-resistant fasteners are included.

- PUMP OPTIONS**
- No Pump**
  - Air Kit Prime**
    - Attached to Fixit
    - Separate
  - Air Kit 4**

- CANE STOP**
- Add Cane Stop** (Galvanized only)

A cane-detectable attachment beneath the hanger arms is available for improved safety. (Additional cost)

