

The Air Kit Prime should be installed with at least 36" of unobstructed access from 3 sides. Allow 18" to the center of the pump if placed next to a wall.

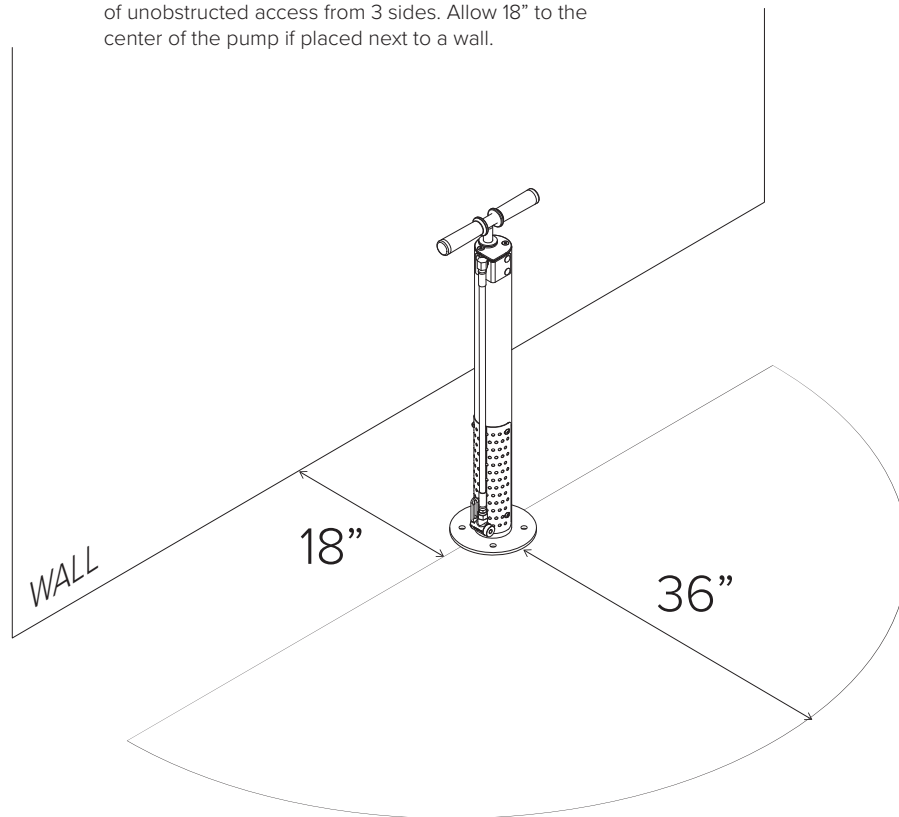



**TOOLS NEEDED**

- Marker or Pencil
- Masonry Drill Bit 3/8"
- Drill (Hammer drill recommended)
- Hammer
- Wrench 9/16"
- Level

**RECOMMENDED BASE MATERIAL**

Solid concrete is the best base material for installation. To ensure the proper anchors are shipped with your Air Kit, ask your Dero representative which anchor is appropriate for your application. Be sure nothing is underneath the base material that could be damaged by drilling.

**1**

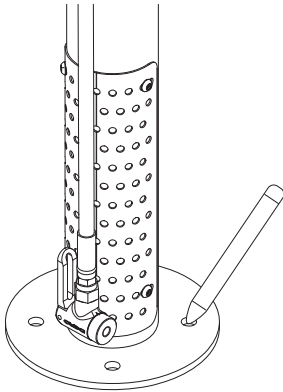

Place the Air Kit Prime in the desired location. Use a marker or pencil to outline the holes of the flange onto the base material.

**2**

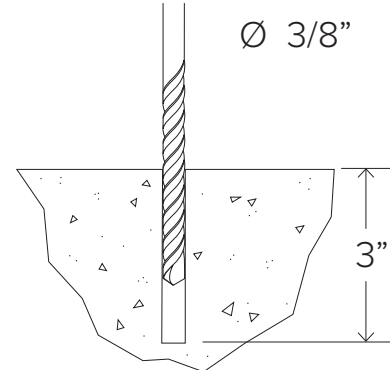

Drill 3/8" diameter holes 3" deep into surface. Make sure the holes are at least 3" away from any cracks in the base material.

**3**

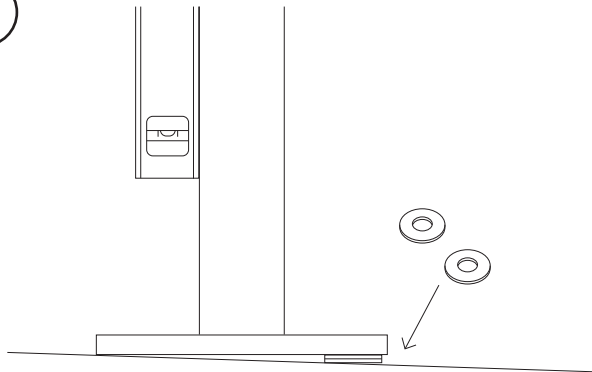

Use washers to level pump if necessary.

**4**

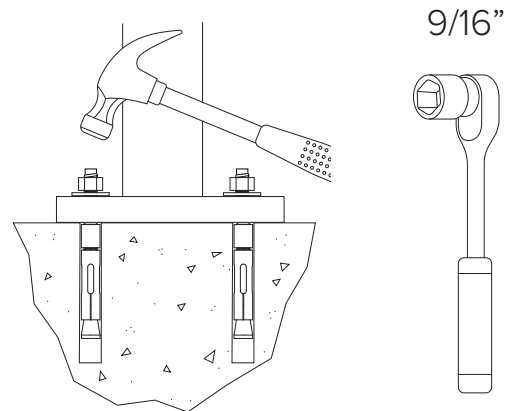

Thread nuts onto anchors, leaving approximately 1/4" of the anchor protruding, and tap into surface. **Place the 2 provided tamper-proof penta nuts on opposite sides.** Tighten nuts down to secure pump.



**Be sure to save your tamper-resistant tools for any future maintenance. They are costly to replace.**

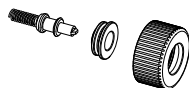

**Because public pumps require occasional maintenance, a spare pump head gasket kit is included with each unit shipped. Save this kit for future use.**

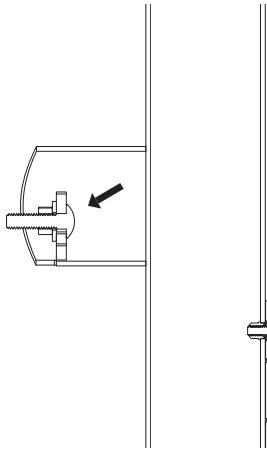
**1**

Firmly attach the carriage bolt to the pump with the nut and washer.

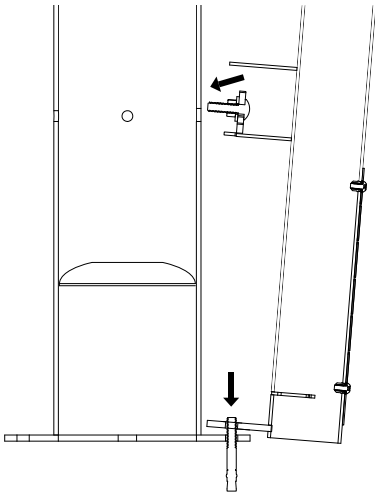
**2**

If attaching to a previously installed Fixit, remove the nut and washer on the wedge anchor on the side of the Fixit to receive the pump. Place the pump lower flange hole over the wedge anchor, and slot the previously attached carriage bolt through the hole on the side of the Fixit.

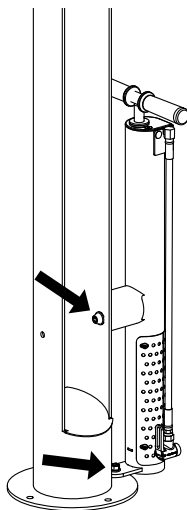
**3**

Loosely secure the carriage bolt with a rubber-backed washer and tamper-proof nut in the inside of the Fixit.

Use the wedge anchor washer and nut to secure the pump flange and then tighten the tamper-proof nut inside the Fixit.

**1**

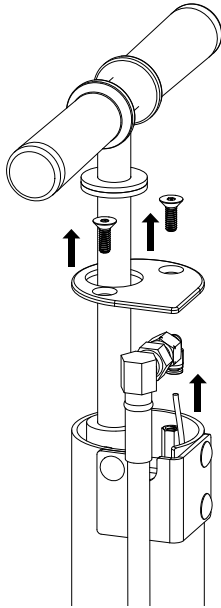

Remove the two tamper-proof screws at the top of the pump and lift the cap. Then disconnect the air line via the push-to-connect fitting at the top of the hose.

**2**

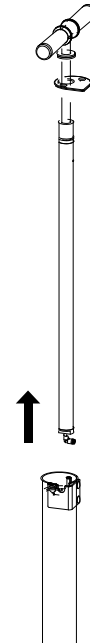

Slide the pump sideways out of the main body slot and then lift the whole pump and air lines out of the main body.

**3**

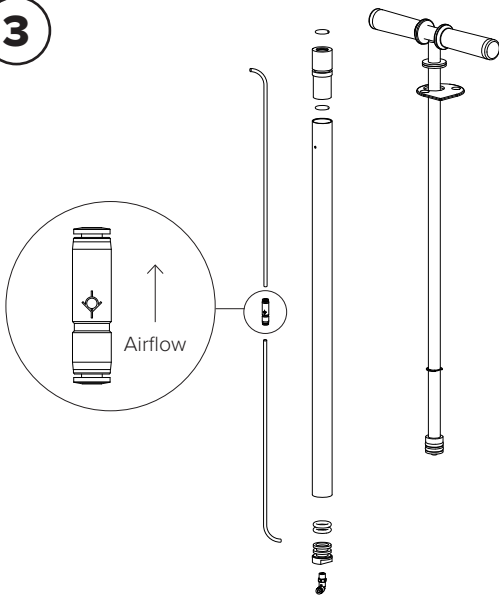

The pump can now be taken apart without tools for servicing.

**4**

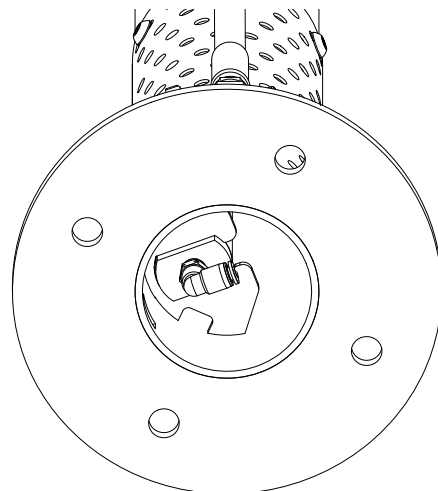

It may be necessary to gain access to the bottom of the main body to align the pump when re-assembling.

Remove Metal Head™ by turning counter-clockwise.  
You will need a 3/4" wrench. Replace with new  
Metal Head and tighten.

