

**TOOLS NEEDED**

Hammer drill  
 3/8" masonry bit  
 Hammer  
 Socket Wrench  
 9/16", 3/4" socket  
 Tamper-proof socket (included)\*  
 Socket extension, 6" min.  
 Razor blade

**RECOMMENDED BASE MATERIAL**

Solid concrete is the best base material for installation. To ensure the proper anchors are shipped with your rack, ask your Dero Rack representative which anchor is appropriate for your application. Be sure nothing is underneath the base material that could be damaged by drilling.



**Be sure to save your tamper-resistant tools for any future maintenance. They are costly to replace.**

**If you are not attaching an Air Kit Prime to your Fixit, proceed to step 4**

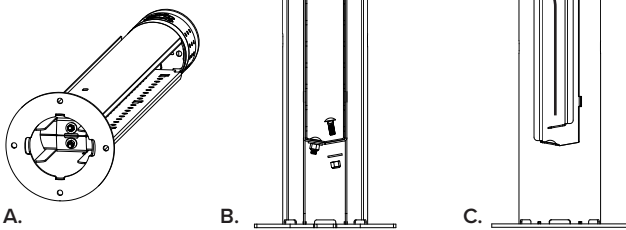
**1**

- A. Lay the Fixit Plus on its side.
- B. Remove one 3/8" carriage bolt, lock nut, and washer.
- C. The guard can then be pushed up and then pulled out. Set the guard aside.

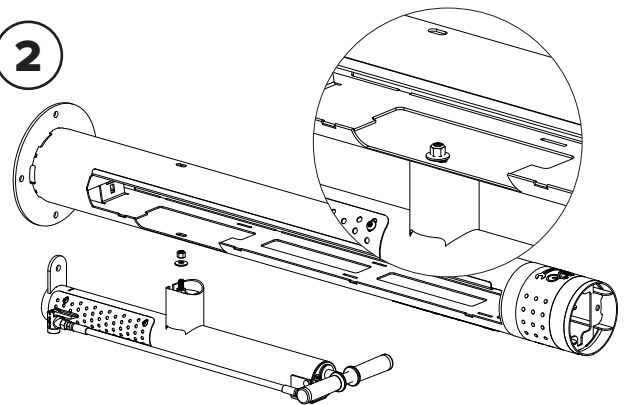
**2**

Secure the Air Kit to the side of the Fixit Plus with the 3/8" threaded stud on the Air Kit and a bonded washer and lock nut inside the Fixit Plus.

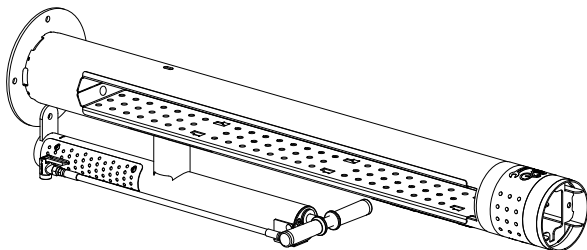
**3**

Re-attach the guard.

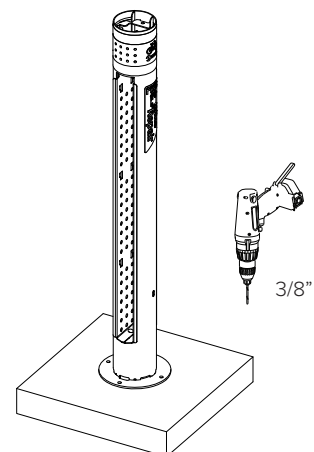
**4**

Reference the Fixit Plus setback recommendations and place the upright in the desired location. Use the base as a template to mark anchor locations and drill (4) 3/8" x 3" holes in the concrete with a hammer drill and masonry bit. Clean up all concrete dust from drilling.



If installing the optional cane stop, place the attachment under the base of the Fixit Plus.

**5**

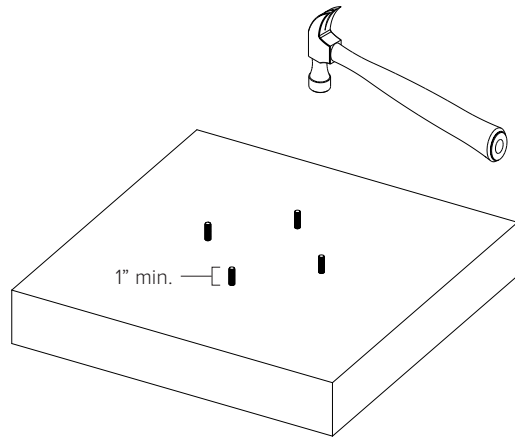

Hammer in the (4) 3/8" wedge anchors. Leave at least 1" inch of exposed threads above the concrete.

**6**

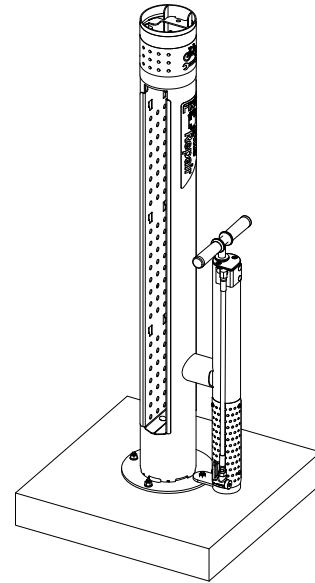

Place the Fixit Plus over the anchors, add washers and nuts, and tighten all nuts.

**7**

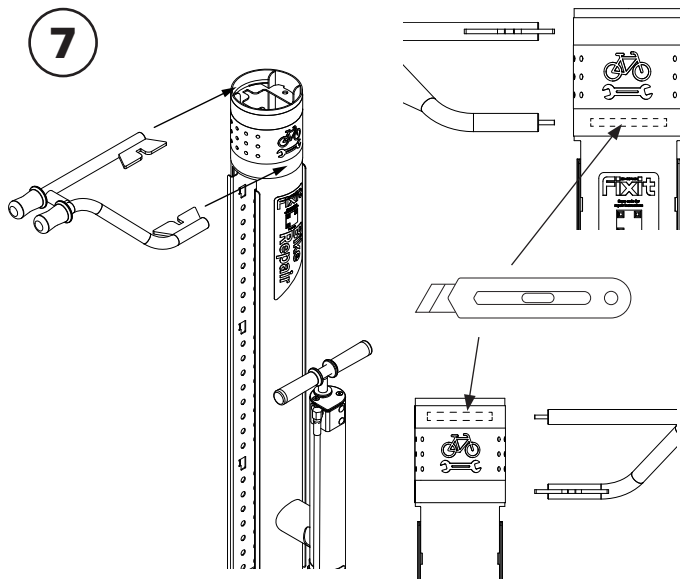

Select the orientation of the bike hanger and use a new razor blade to cut through the decal to reveal the corresponding slot in the Fixit Plus.

**8**

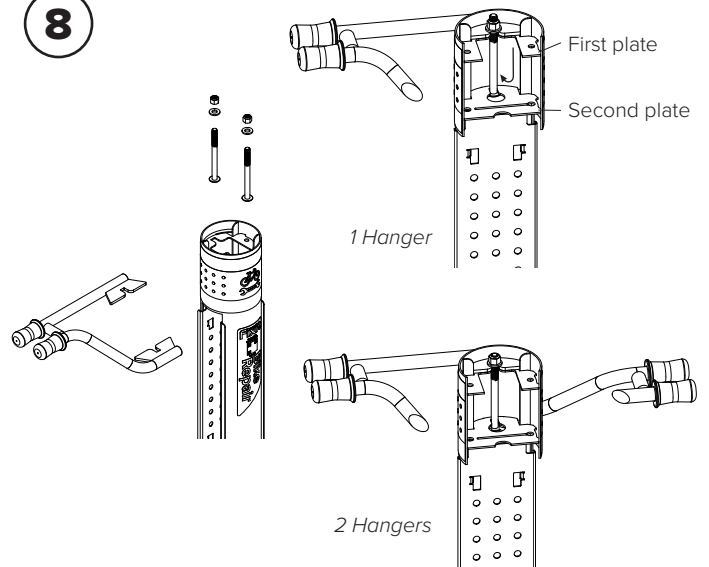

Add the 1/2" washer and 1/2" lock nut to the 1/2" x 6" carriage bolt. Insert the assembled hardware, headfirst, into the top of the Fixit Plus. The carriage bolt head will pass through the second plate hole and then slide sideways, so the carriage bolt engages the slot in both plates and bike hanger. Tighten the lock nut and repeat with the other side. If two bike hangers are used, the carriage bolt will also engage the second bike hanger under the second plate.

**9**

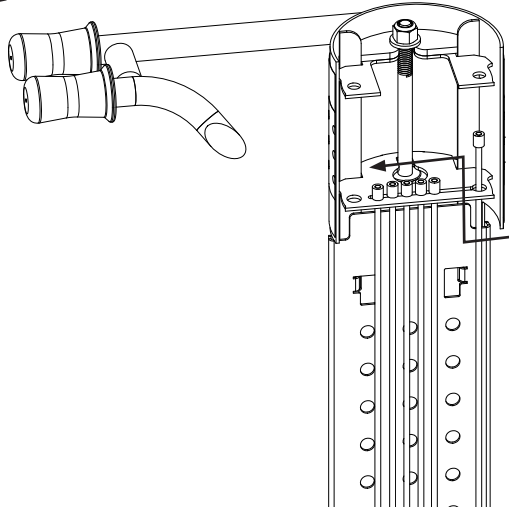

Insert the tool cables into the cable slot in the Fixit Plus upright.

**10**

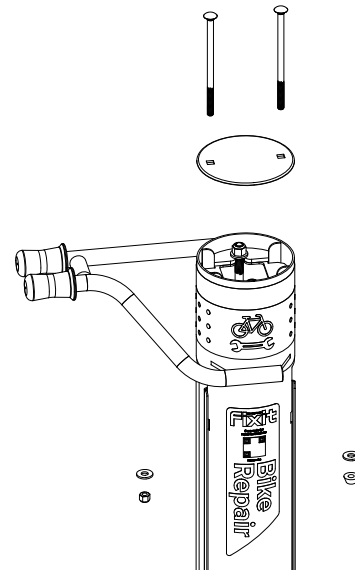

Place the top cap on the Fixit Plus and insert the (2) 3/8" x 7" carriage bolts through the top cap, first plate, and second plate of the Fixit Plus. Secure the carriage bolts with washers and nuts. The Penta nut goes over the hole the tool cables were inserted into.

**Concrete foundation recommendations**

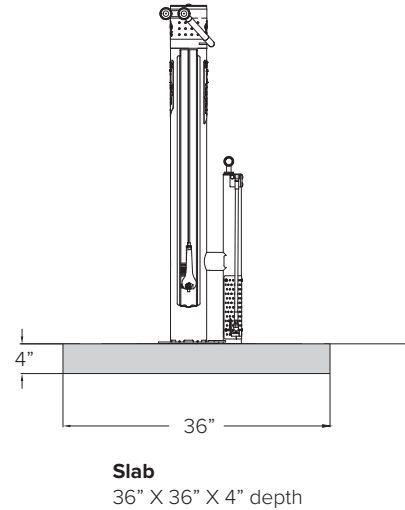
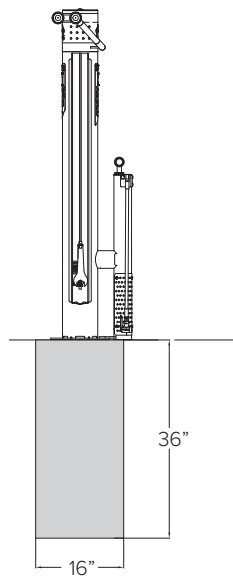

**Put Your Station on the Map!**

If you would like us to add your station to our online map, email the station's geocoordinates to [web@dero.com](mailto:web@dero.com). These coordinates can be obtained by simply clicking a point on a Google Map.

<http://www.dero.com/fixitmap/fixitmap.html>



See diagrams below for guidance on installing the optional Cane Stop. This attachment provides a cane-detectable barrier beneath the hanger arms of the Fixit for improved safety.

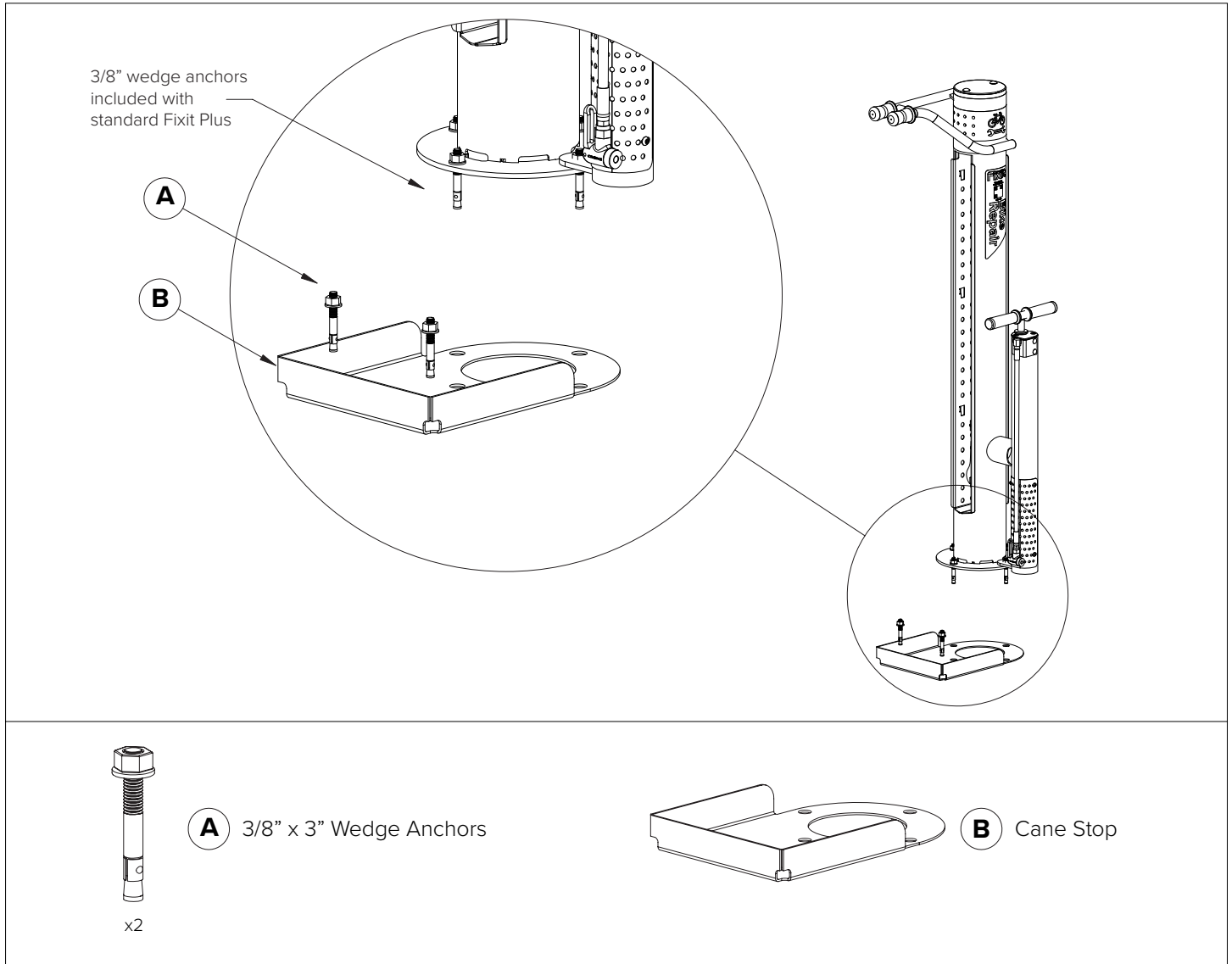

**NOTE**

All threads for all parts of the pump are right-hand threads. They tighten clockwise, and loosen counter-clockwise ("righty tighty, lefty loosey"). However, when you are looking top-down at a bolt that threads from underneath, if you move it counter-clockwise from your point of view, you are actually tightening, not loosening, the nut! This has led to some unnecessary breakage of pump parts. Be sure you are looking at the nut with the proper orientation before tightening or loosening.

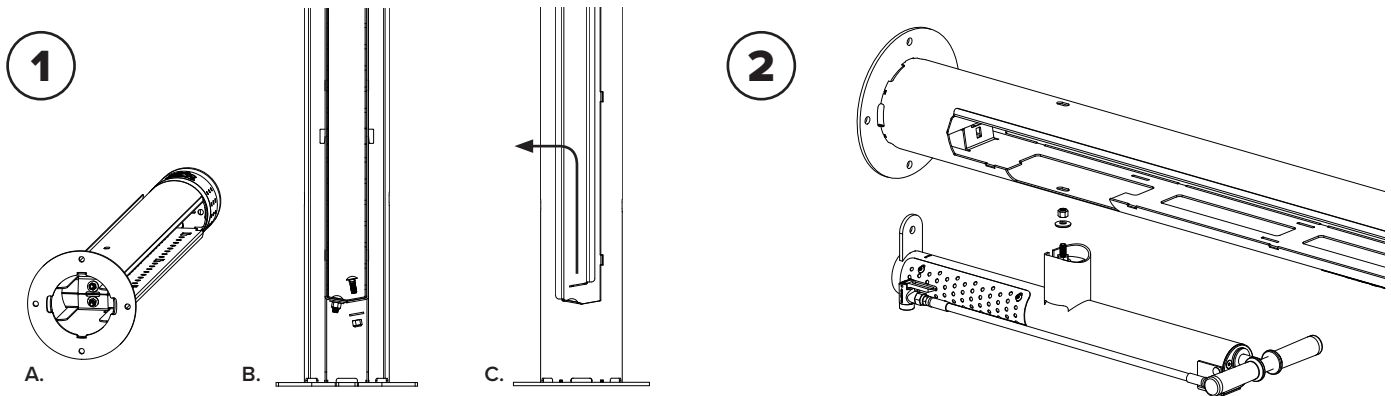
**REMOVING THE AIR KIT FROM THE FIXIT PLUS**

- (A) Lay the Fixit Plus on its side.
- (B) Remove one 3/8" carriage bolt, lock nut, and washer.
- (C) The guard can then be pushed up and then pulled out. Set the guard aside.

Remove nut attaching the Air Kit to the side of the Fixit Plus.

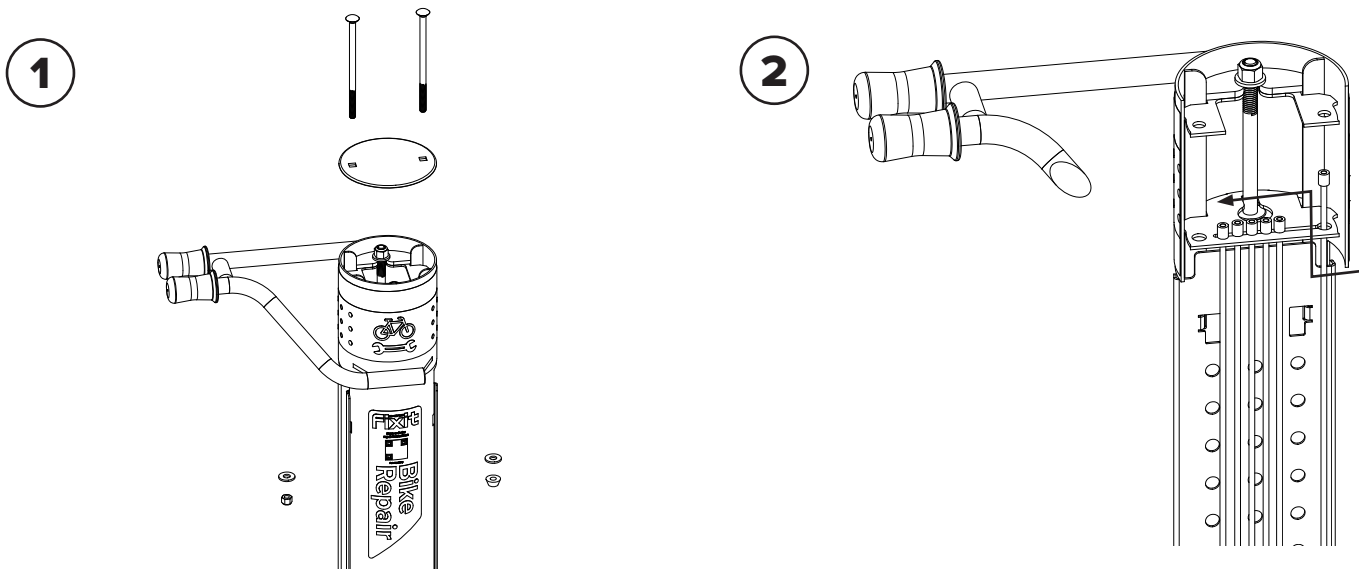
**REPLACING TOOLS**

Remove the 3/8" nut and penta tamper-proof nut from the underside of the top compartment and lift out the carriage bolts. These are all best removed with a socket wrench, using the extension tool to enable you to reach the nuts.

Add or remove tools by sliding the tool cables through the hole at the end of the cable slot in the Fixit Plus upright.