



DERO
A PLAYCORE Company



Smart **Bike Locker**

Powered by **bikeep**

The Smart Bike Locker powered by Bikeep is about more than just security – it's a reflection of our dedication to a smarter, more connected future. With easy smartphone access for users and a robust console for administrators, our app-operated locker does away with lost keys and passcodes to create a seamless, intuitive bike parking experience. Add optional charging ports to let e-bike riders begin every trip with full power.



Easy access through the Bikekeep smartphone app

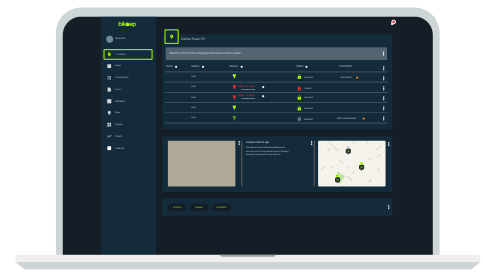

Smartphone Access for Cyclists

The app enables cyclists to join and use the full potential of the integrated network. Cyclists can conveniently plan commutes and reserve their parking spots ahead of time. Through the easy-to-use Bikekeep app, responsive customer support is at the cyclists' fingertips.

Advanced Console for Admins

Bikekeep's Console gathers real-time and statistical information about locations, parking usage, and cyclists. It allows you (the operator) to remotely manage access, including lock/unlock, payment options, and surveillance.

FINISH OPTIONS

Powder Coat

- | | | | |
|-------------------------------------------------------------------------------------------------------------|-------------------------------------------------------------------------------------------------------|------------------------------------------------------------------------------------------------------------|---------------------------------------------------------------------------------------------------------------|
|  White |  Black |  Light Gray
RAL 7042 |  Deep Red
RAL 3003 |
|  Orange
RAL 2004 |  Beige
RAL 1001 |  Iron Gray
RAL 7011 |  Hunter Green
RAL 6005 |
|  Light Green
RAL 6018 |  Green
RAL 6016 |  Blue
RAL 5005 |  Sky Blue
RAL 5015 |
|  Sepia Brown
RAL 8014 |  Dark Purple |  Wine Red
RAL 3005 |  Bronze |



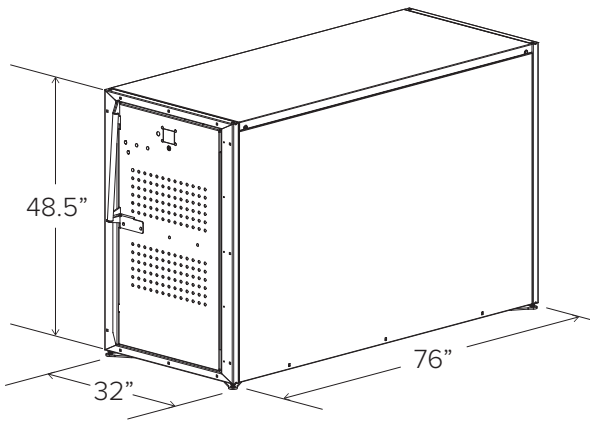

CAPACITY 1 Bike

MATERIALS
Frame: 1.50" x 3.00" x 14g tube
Floor: 18g plate
Sides: 18g plate
Doors: 16g plate
Top: 18g plate

FINISHES
Locker Frame: Galvanized
Panels and Doors: Powder coat over G90 electro plated steel

LOAD DATA 40 psf snow, 90 mph wind exposure B, high seismic

SETBACKS Allow a 60" clearance from door face.

- STANDARD**
- Leveling feet
 - Floor panel
 - Ventilating window on doors
 - Graffiti resistant
 - UV resistant
 - Numbering
 - Gear hook
 - Door closer

- E-BIKE CHARGING**
- Non-Charging (No Outlets)**
 - Add Charging Port with 4-Hour Timer**

** Charging and non-charging lockers both need 110v electrical supply to one locker per connected set (max 10).*

- CAMERA**
- Optional Security Camera**
 Motion-captured security images accessible remotely.
 Captured video available upon request or by accessing the SD card.
 (1 camera per set of connected lockers).

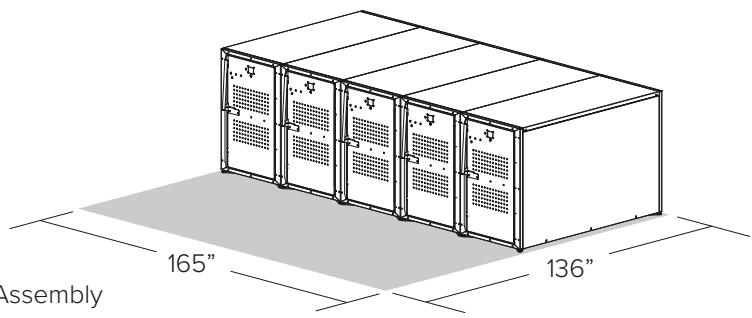
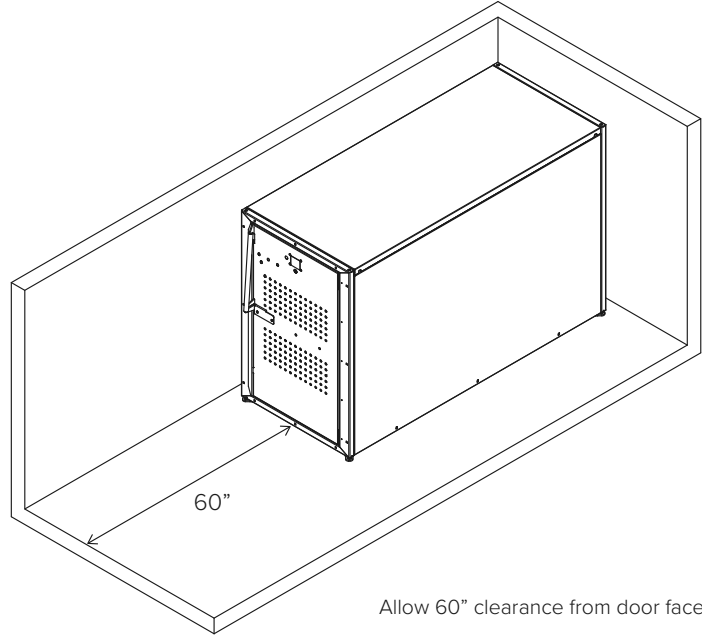
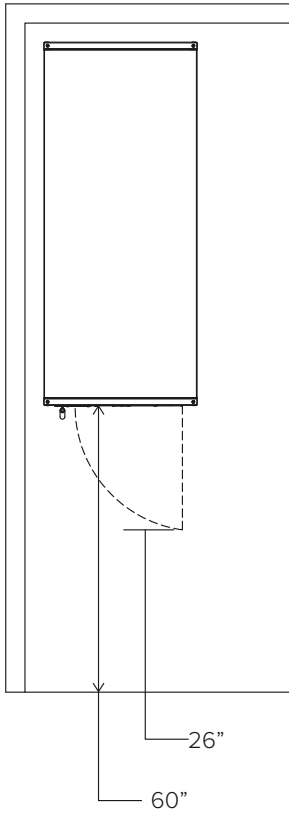

5 Locker Assembly

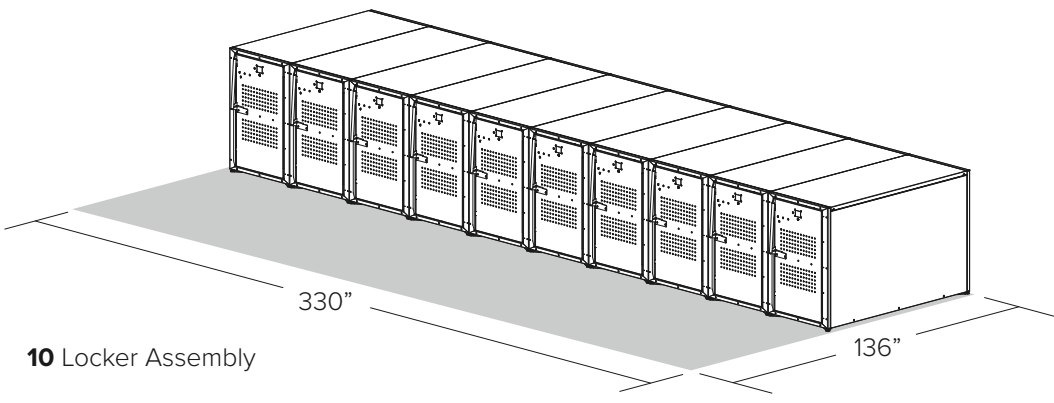

10 Locker Assembly

Site Validation and Preparation Basics

Selecting the optimal location for a set of lockers is essential for attracting and retaining cyclists, as well as minimizing installation and maintenance costs. This document outlines the guidelines and requirements for selecting, validating, and preparing a locker location.

SMART BIKE LOCKERS POWERED BY BIKEEP

Bikeep smart bike lockers are a complete product solution for safe and seamless personal bicycle parking in city-wide station networks.



Each smart bike Locker location consists of the following:

- A **main controller** in one of the lockers for 4G internet connection and real-time data.
- Up to 10 individual lockers per controller.
- An **electrical connection** to one locker at the end of a row.
- An **optional security camera** for increased security that can be installed anywhere near the station.

Dero provides all parts for assembly. Clients need only to supply electricity to one locker in each connected set.

LOCATION RECOMMENDATIONS

When choosing a location for lockers, consider the following:

- **Visibility:** Place lockers in highly visible locations, such as next to main entrances, to attract attention.
- **Accessibility:** Ensure easy access to the electrical supply and stay within 165 feet of key destinations.
- **Convenience:** Do not obstruct pedestrian paths and avoid stairwells for cyclists.
- **Strategy:** If a building has two or more main entrances on opposite sides, provide lockers at each doorway.
- **Connectivity:** A 4G mobile internet connection must be available at the site to provide real-time data on locations, parking usage, and cyclists.
- **Electricity:** 110VAC power to the location should be handled by a qualified electrician in accordance with local standards and regulations.

GROUND REQUIREMENTS

Bikeep Smart Bike Lockers have been designed to be installable both indoors and outdoors.

They can be installed on any hard surface by one of the two following options:

- **Type 1:** Making use of a **preexisting concrete** surface with a thickness of at least 4 inches
- **Type 2:** Pouring a **new concrete** surface

Lockers cannot be installed on dirt, grass, sand, or similar surfaces. The ground must be solid, flat, and have an incline of no more than 1.5 degrees.



Install lockers within the following slope guidelines

Maximum Ground Slope		
# of Lockers in Assembly	Lockers Level	Lockers at 1° Angle
5	0.6%	3.0%
10	1.3%	1.8%

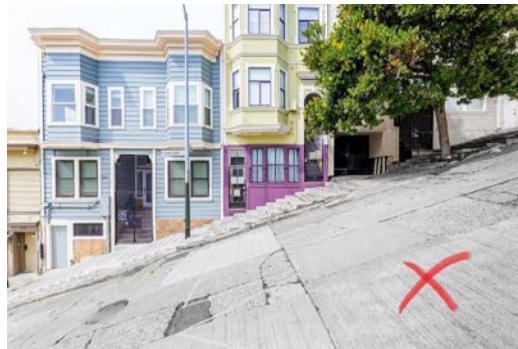

Lockers bolted to an existing hard surface (Type 1)



Requirement: Concrete pavement thickness at least 4 inches and not cracked



Lockers bolted to the ground with a new concrete surface creation (Type 2)



Requirement: Ground removable for concrete base creation (asphalt, cobblestone, dirt, etc)



ELECTRICAL REQUIREMENTS FOR CHARGING LOCKERS

All connected sets of up to 10 lockers need a **110 VAC** (volts alternating current) power line; standard U.S. power supply. Power is typically sourced from nearby buildings or electrical breaker boxes.

Dero provides all parts for assembly. Clients need only to supply supply a power line with conduit/fittings into the initial locker for the assembly.



110VAC power to the location should be handled by a qualified electrician in accordance with local standards and regulations.

Input voltage: **110VAC**

# of lockers	Power consumption	Power requirement for e-charging
5-locker station	Peak: 2.2kW Typical: .75kW	20A @110VAC
10-locker station	Peak: 4.4kW Typical: 1.5kW	40A @110VAC (2 circuits, 20A each)

*Calculations are based on 4 amp chargers that are charging at full load.
The actual power consumption may differ.*

**ELECTRICAL
REQUIREMENTS FOR
NON-CHARGING
LOCKERS**

All connected sets of up to 10 lockers need a **110 VAC** (volts alternating current) power line; standard U.S. power supply. Power is typically sourced from nearby buildings or electrical breaker boxes.

Dero provides all parts for assembly. Clients need only to supply electricity for the station.



110VAC power to the location should be handled by a qualified electrician in accordance with local standards and regulations.

Input voltage: **110 VAC**

# of Docks	Power consumption	Power requirement
5-locker station	15W	Less than 1A @110VAC
10-locker station	20W	



TOOLS NEEDED

- Hammer drill with 3/8" masonry bit
- Hammer
- Bubble level
- Tape measure
- 3/8", 7/16", 1/2", 9/16" wrenches
- Socket wrench
- 3/8", 7/16", 1/2", 9/16" sockets
- Power drill
- #3 Phillips screwdriver bit
- Needle-nose pliers
- Socket Extension
- Small side-cutter pliers

RECOMMENDED BASE MATERIAL

Solid concrete is the best base material for installation. To ensure the proper anchors are shipped with your locker, ask your Dero representative which anchor is appropriate for your application. Be sure nothing is underneath the base material that could be damaged by drilling.

1

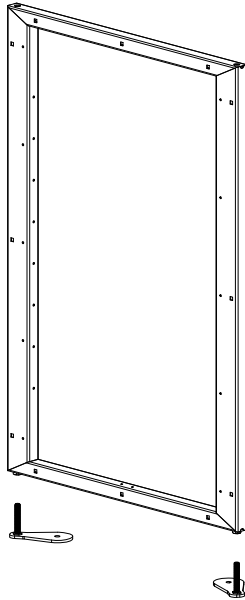

Thread (2) leveling feet into each door frame.

2

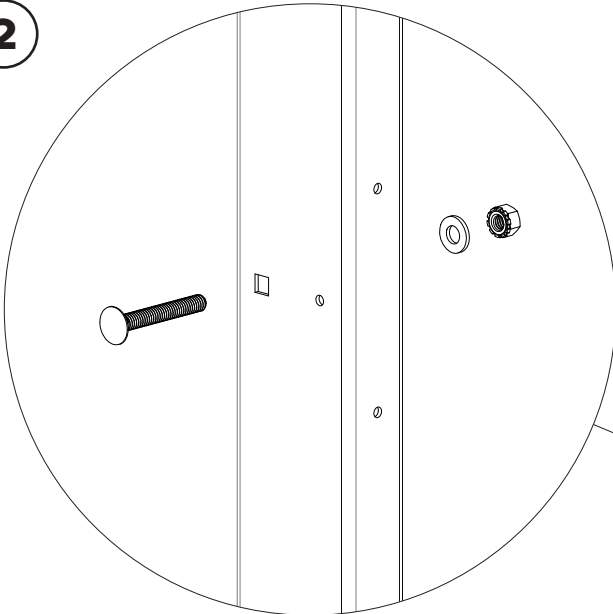

Attach (2) side panels to the (2) door frames with (12) 5/16" x 2.25" carriage bolts, washers, and nuts. Omit the (4) bottom bolts for now. Leave nuts finger-tight

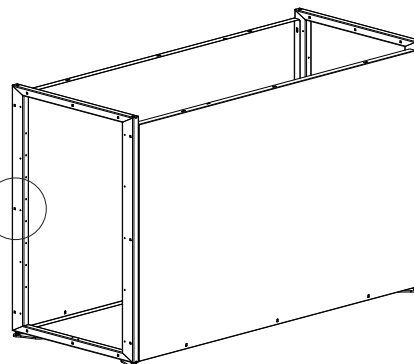

3

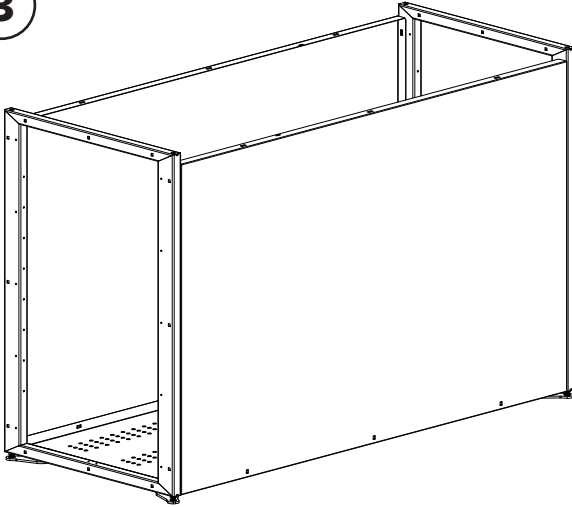

Place the floor panel in the locker and attach to the side panels with (6) 5/16" x .75" carriage bolts, washers, and nuts. Attach to the door frames with (6) 5/16" x 2.25" carriage bolts, washers, and nuts. Add the remaining (4) 5/16" x 2.25" carriage bolts, washers, and nuts that attach the side panels to the door frames. Leave all nuts finger-tight.

4

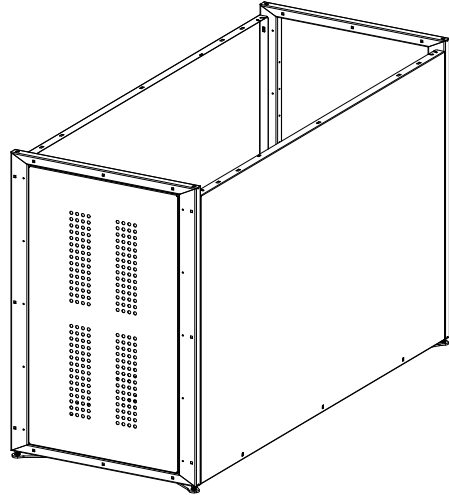

Attach the back panel to the rear door frame with (10) #12 x 3/4" self-drilling screws. Pilot holes are present but may be partially filled with zinc. Screwing is done from inside the locker. Set the power drill clutch to a high setting but not locked. The final tightening should be done by hand with a #3 Phillips driver. **Do not use an impact drill** or the threads will be stripped.

5

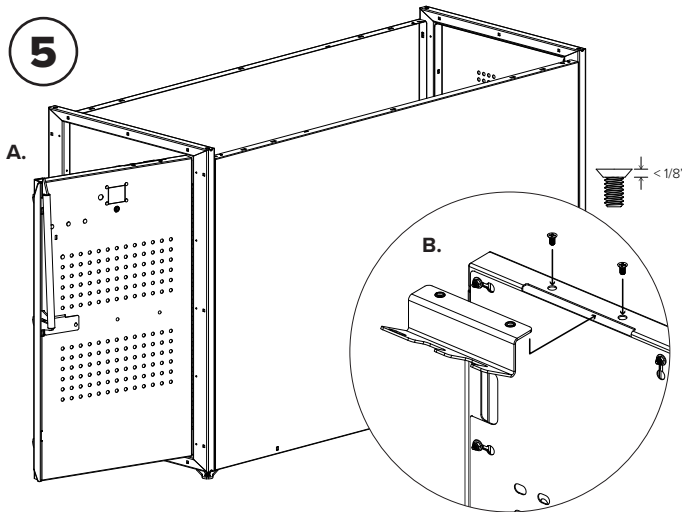

A. Attach the door assembly with (8) #12 x 3/4" self-drilling screws. Pilot holes are present but may be partially filled with zinc. Set the power drill clutch to a high setting but not locked. The final tightening should be done by hand with a #3 Phillips driver. **Do not use an impact drill** or the threads will be stripped.

B. Attach the door spring/gear hook to the door with (2) 1/4" x 1/2" undercut screws.

6

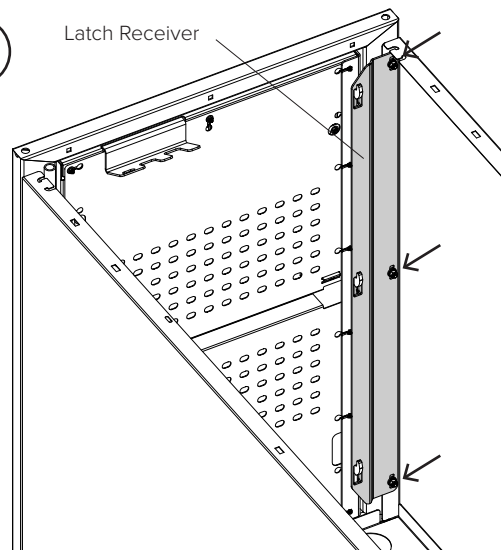

Attach the latch receiver by removing the (3) nuts on the inside-left of the door frame (these are the nuts that hold the side panel on). Place the latch receiver on the (3) bolts and fasten with the (3) nuts finger-tight.

7

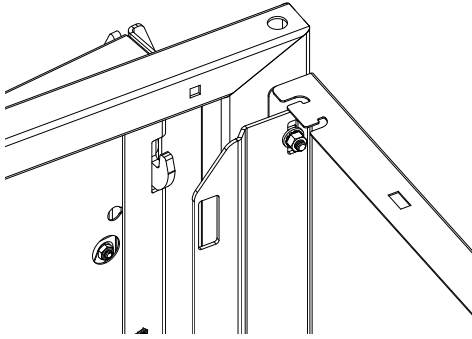

A

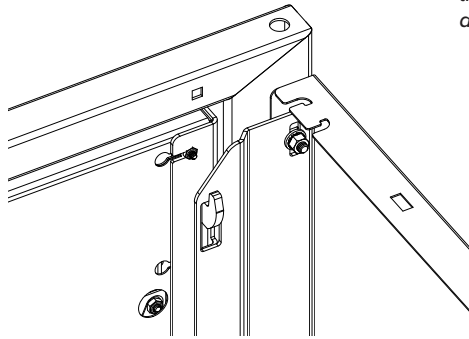

B

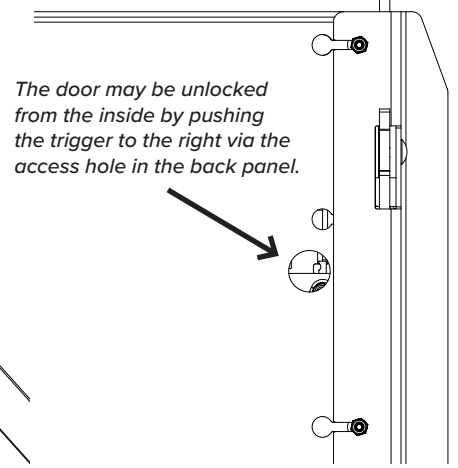

The door may be unlocked from the inside by pushing the trigger to the right via the access hole in the back panel.

C

Unlock the door so the latch is lowered and shut the door. Confirm the latch hooks can pass through the slots in the latch receiver. Lift the door handle and confirm the latch locks without interference from the receiver. Tighten the (3) nuts attaching the latch receiver. Confirm the unlock and lock procedure one final time.

8

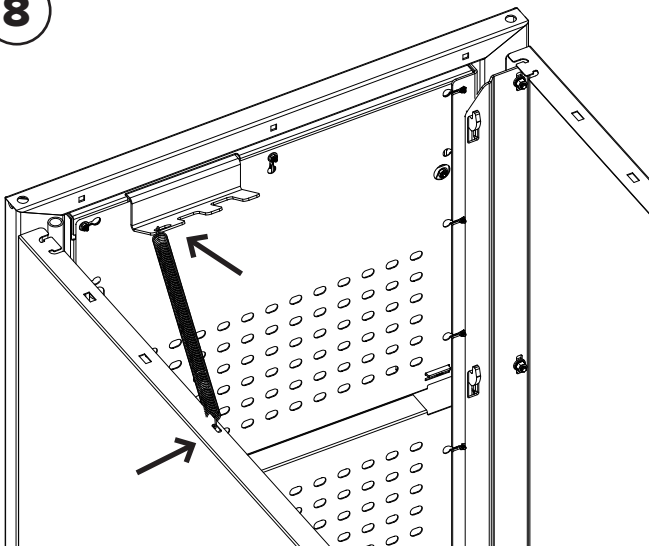

Attach the door closing spring to the door spring/gear hook bracket and side panel. A needle-nose pliers is helpful.

9

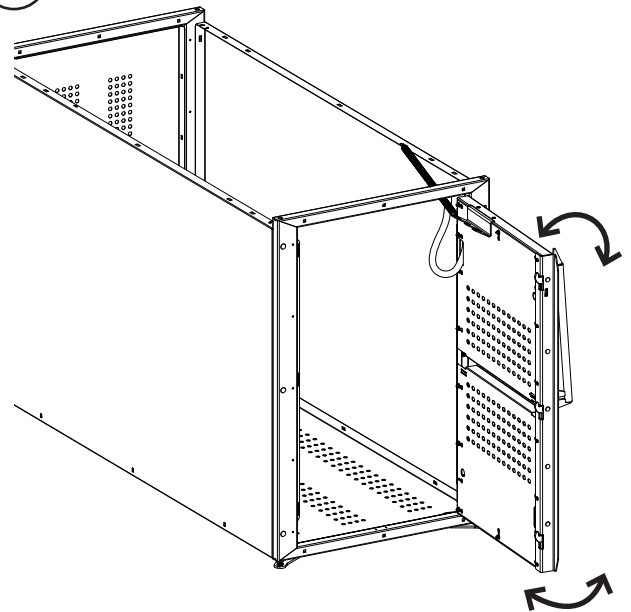

If any twist needs to be taken out of the door, loosen the #10 locknuts, set the door, and re-tighten.

10

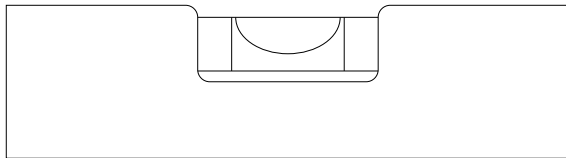

Level the locker with the leveling feet, check squareness, and tighten all the 5/16" nuts attaching the side panels, door frames, and floor.

11

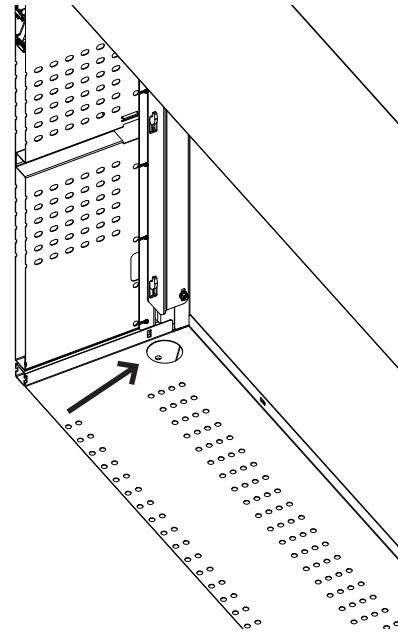

Secure the locker to the ground with (4) anchors. The leveling foot anchor holes should line up with the large holes in the locker floor.

Use wedge anchors for installation on concrete, or Titen anchors for asphalt surfaces. Contact Dero if you do not have the appropriate anchors for your installation surface.

12

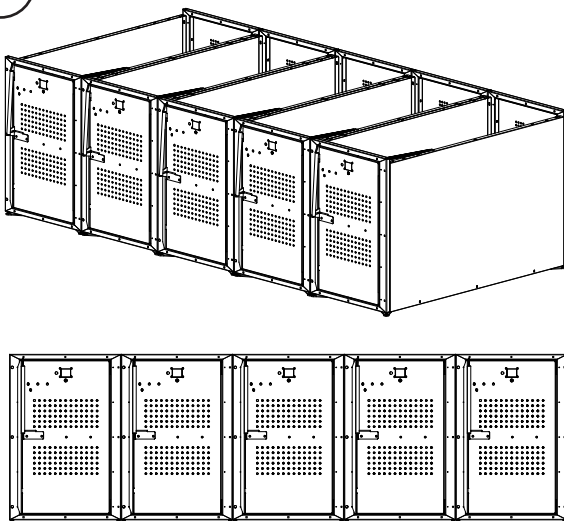

If a row of lockers is to be installed, build the others in the same way and position them directly next to each other with all lockers in a row at the same height. None of the lockers have roofs at this point.

13

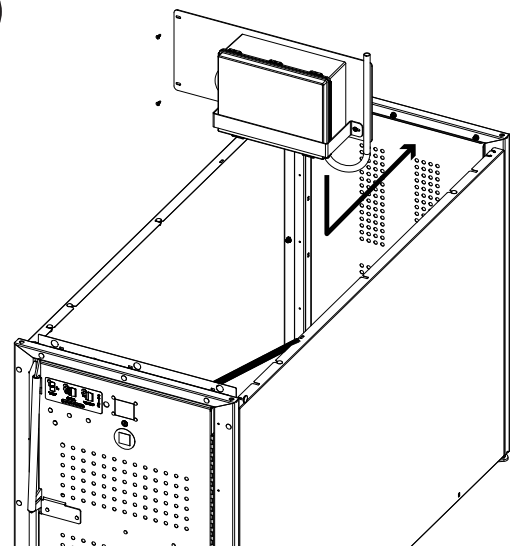

The first locker will contain the Bikeep main control unit (MCU). Place the MCU holder against the back frame and secure with (4) #12 x 3/4" self-drilling screws and washers. Pilot holes are present but may be partially filled with zinc. Screwing is done from inside the locker. Set the power drill clutch to a high setting but not locked. The final tightening should be done by hand with a #3 Phillips driver. Do not use an impact drill or the threads will be stripped.

14

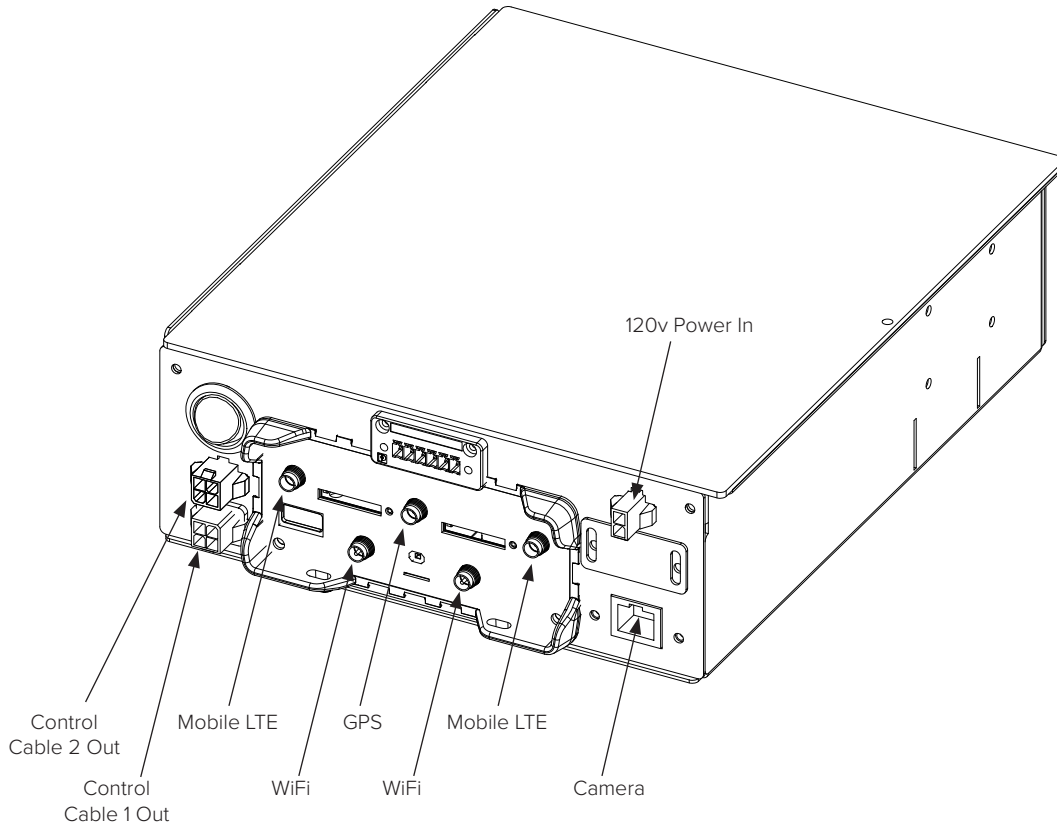

15

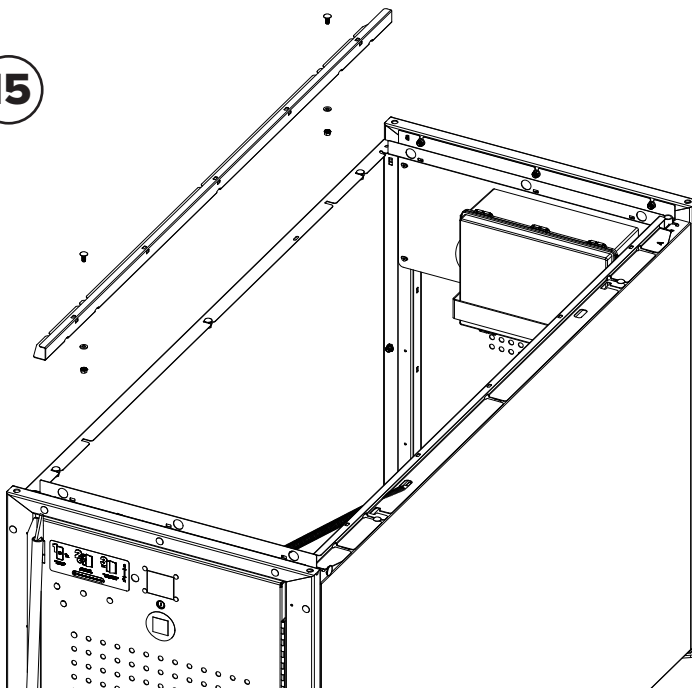

Attach the (2) side cable guards and secure with (2) 5/16" x 3/4" carriage bolts, washers, and lock nuts. Note the specific holes.

16

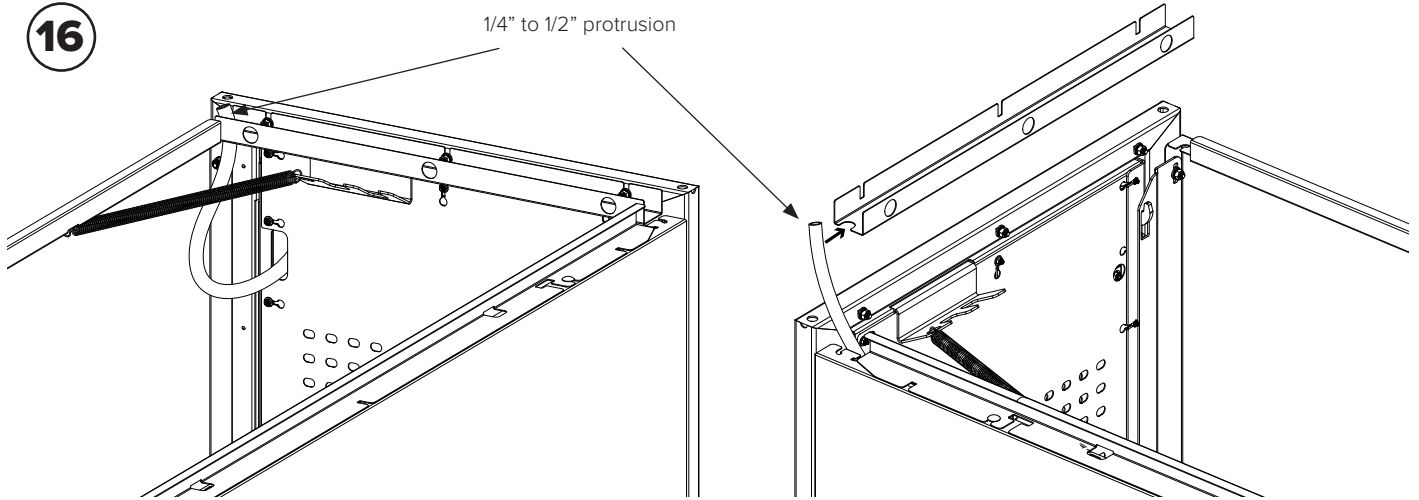

Attach the front cable guard and secure with (3) 5/16" x 2.25" carriage bolts, washers, and nuts. Before placing the front cable guard, slide the flexible conduit from the door into the side slot of the cable guard. When the cable guard is secured, the flexible conduit should be held captive. Give it a tug to confirm.

17

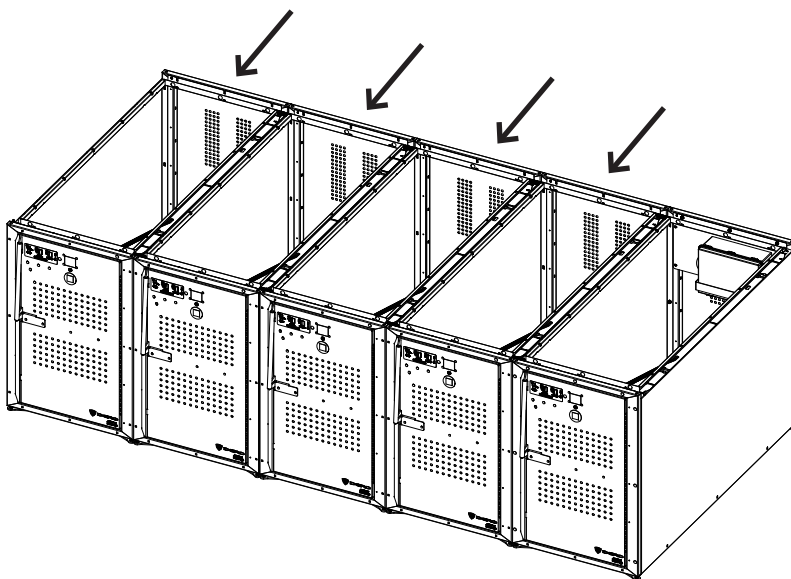

Repeat steps 15-16 for the remaining lockers in the set. In addition, a front cable guard is secured to the top of each rear frame. Before placing the initial rear cable guard, slide the flexible conduit from the MCU box into the side slot of the cable guard. When the cable guard is secured, the flexible conduit should be held captive. Give it a tug to confirm.

18

Place the short lengths of flexible conduit at the front and rear of lockers where they are adjacent. Use zip-ties with the cutout features in the side panel to loosely hold them in place.

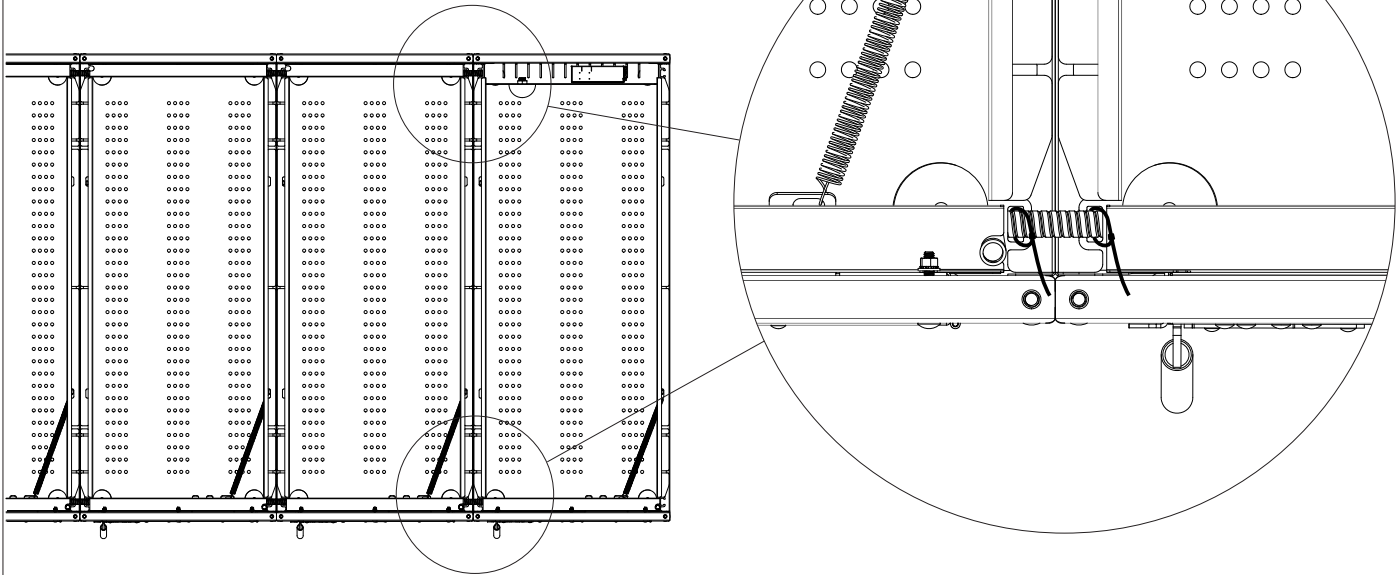

19

Remove the MCU box security strap by removing the (2) 1/4" tamper-resistant screws with a 5/32" pin-in-hex security bit (included). Route the long cable from the door to the MCU via the side cable guard and the flexible conduit into the MCU box. Connect the cable to the MCU plug labeled "CAN 1." Zip-ties should be used along the cable guard with the provided slots to hold the cables out of the way. Trim zip-tie tails.

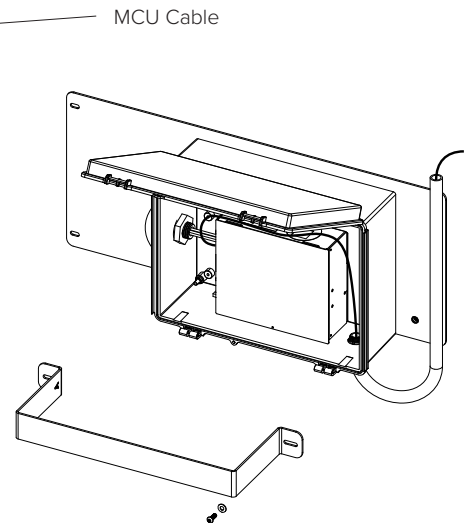
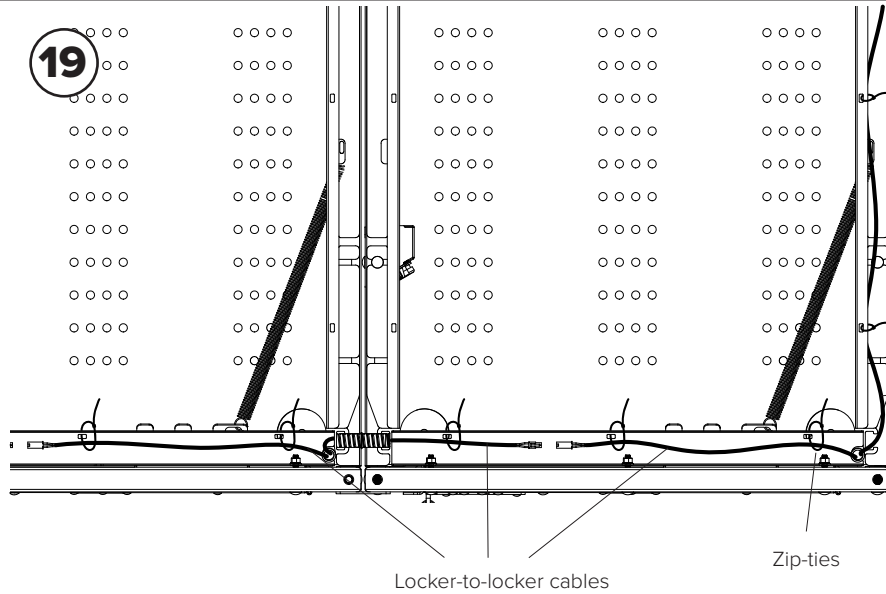

20

Run the locker-to-locker cable from the next locker through the short length of conduit and connect it to the cable from the previous locker. Repeat this for the remaining locker cables.

21

Connect the MCU to 120V power, turn the MCU on with the toggle switch, wait a few minutes, and test each locker to confirm Bikeep functions. Test each door with the mechanical key to confirm the mechanical override functions.

22

If the lockers include e-bike charging, a licensed electrician will install the receptacle and timer.

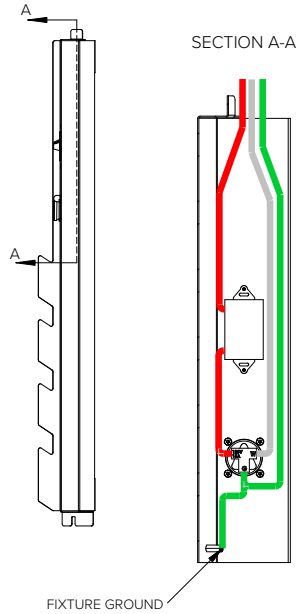

ALL ELECTRICAL WIRING TO BE PERFORMED BY A LICENSED ELECTRICIAN IN ACCORDANCE WITH NEC OR THE LOCAL CODE

ALL WIRES AND CONDUIT SUPPLIED BY INSTALLER

1. ROUTE ELECTRICAL WIRES THROUGH THE LOCKER FIXTURE.
2. FASTEN THE ELECTRICAL TIMER TO THE FIXTURE WITH (2) SCREWS.
3. ROUTE THE POSITIVE WIRE THROUGH THE TIMER AND THEN TO THE RECEPTACLE.
4. CONNECT ELECTRICAL WIRES TO THE RECEPTACLE.
5. FASTEN THE RECEPTACLE AND GASKET TO THE FIXTURE WITH (4) SCREWS AND NUTS.
6. ATTACH THE GROUND WIRE WITH #10 RING LUG TO FIXTURE GROUND WITH A #10-24 SCREW + TOOTH WASHER.
7. CONNECT POWER AND NEUTRAL WIRES TO GCFI CIRCUIT BREAKER 125V/15A MAX.

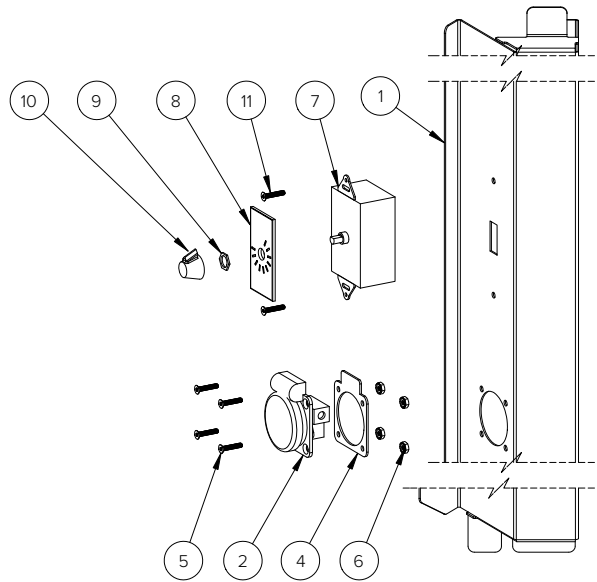

ITEM NO.	PART NUMBER	QTY.
1	LOCKER CHARGING BOX 600112-A	1
2	INTERNATIONAL CONFIGURATIONS 15 Amp, 125 Volt, NEMA 5-15R, Single Receptacle, 70020	1
4	INTERNATIONAL CONFIGURATIONS 15 Amp, 125 Volt, NEMA 5-15R, Single Receptacle, 70020, Gasket	1
5	BOLT 6-32 X .75, FLAT, PIN-IN-TORX	4
6	NUT 6-32, TOOTHED WASHER	4
7	ELECTRICAL TIMER	1
8	ELECTRICAL TIMER FACE PLATE	1
9	ELECTRICAL TIMER NUT	1
10	ELECTRICAL TIMER KNOB	1
11	BOLT 6-32 X .75, FLAT, PIN-IN-TORX	2

23

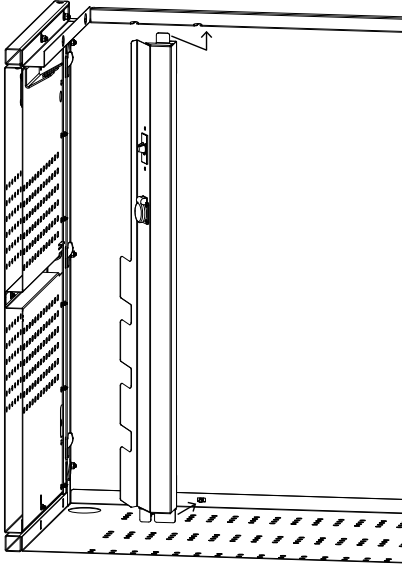

Remove the 5/16" nut and washer at the bottom of the left side panel, nearest the door. Feed the power wires through the slot in the cable guard and fit the tab on the charging fixture into the same slot. Lower the bottom of the charging fixture so the bottom slot meets the 5/16" carriage bolt at the panel bottom. Note the power wires aren't pinch and tighten the 5/16" nut and washer. Zip-ties should be used along the cable guard with the provided slots to hold the wires out of the way. Trim zip-tie tails.

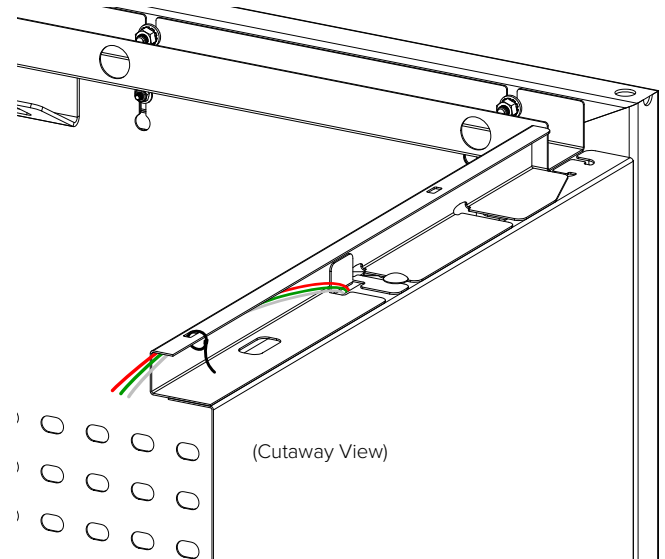
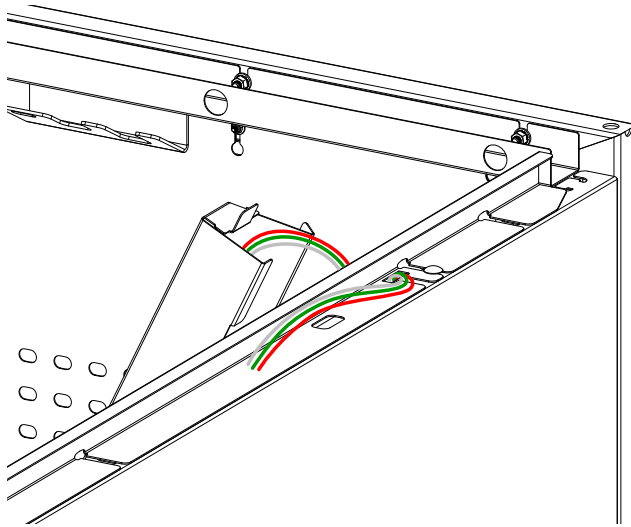

24

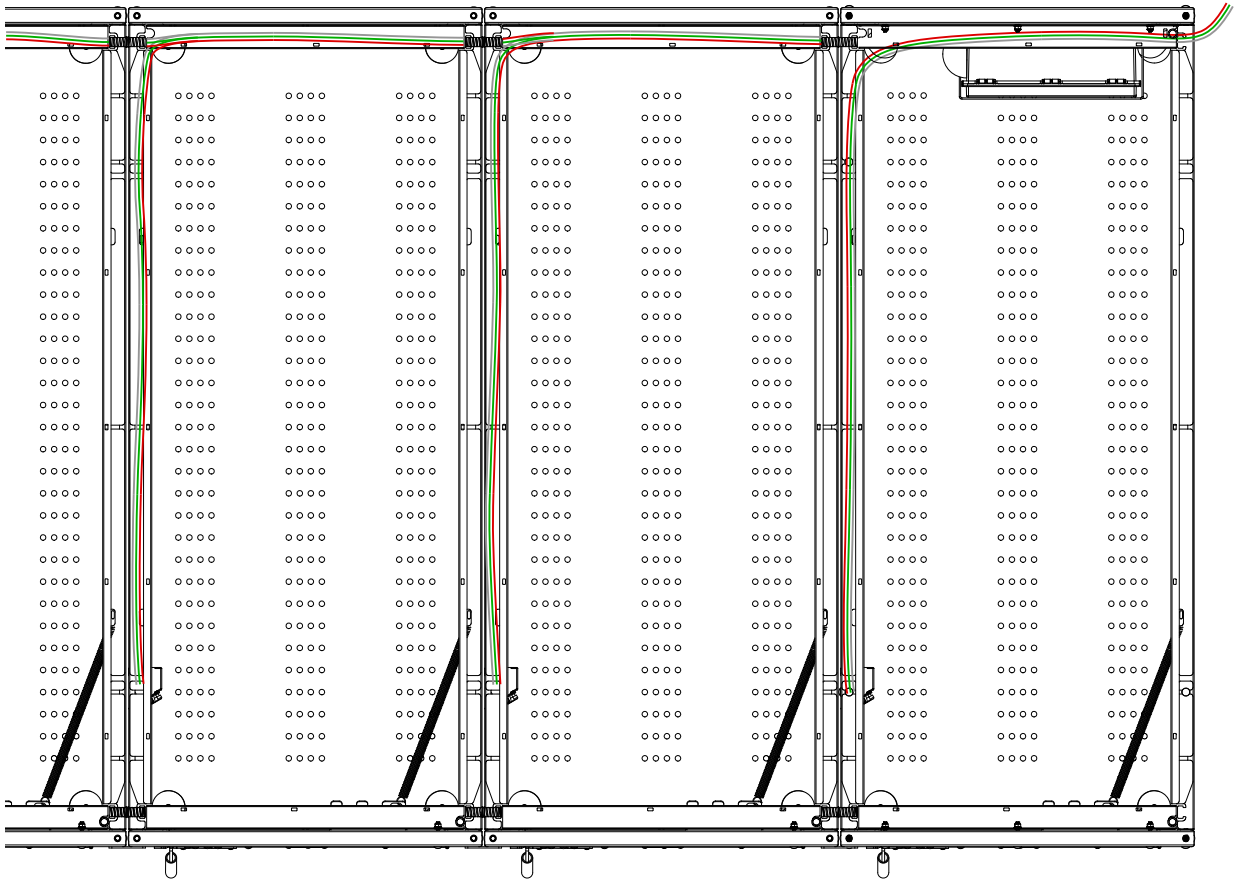

Repeat for remaining e-bike charging outlets and run power wires to the rear of the lockers, through the short flexible conduit, and to the power entry point.

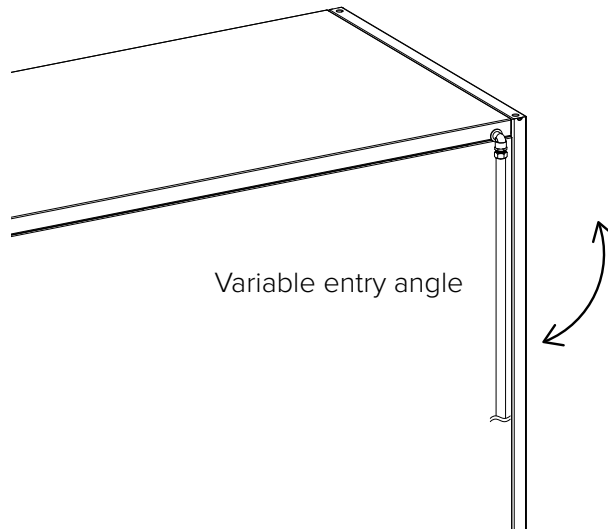

25

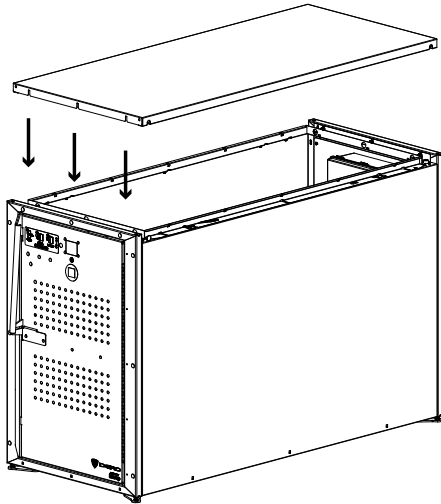

Loosen the (3) 5/16" nuts holding the front cable guard on and lower the roof panel into place. The front flange of the roof panel will fit between the door frame and front cable guard. If flexible conduit between lockers is present, the cutouts in the roof panel will fit over it and hold it captive.

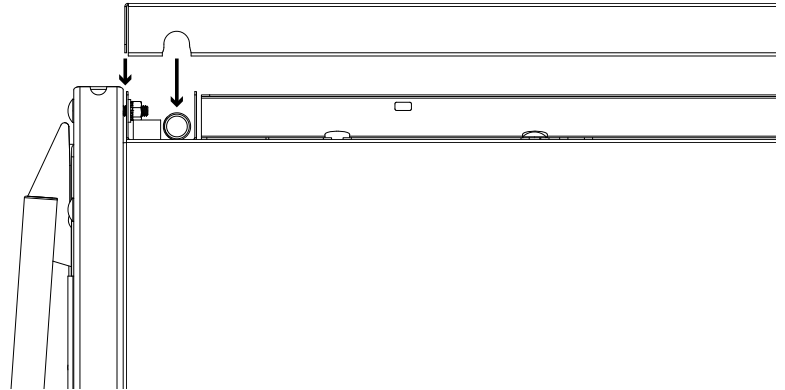

26

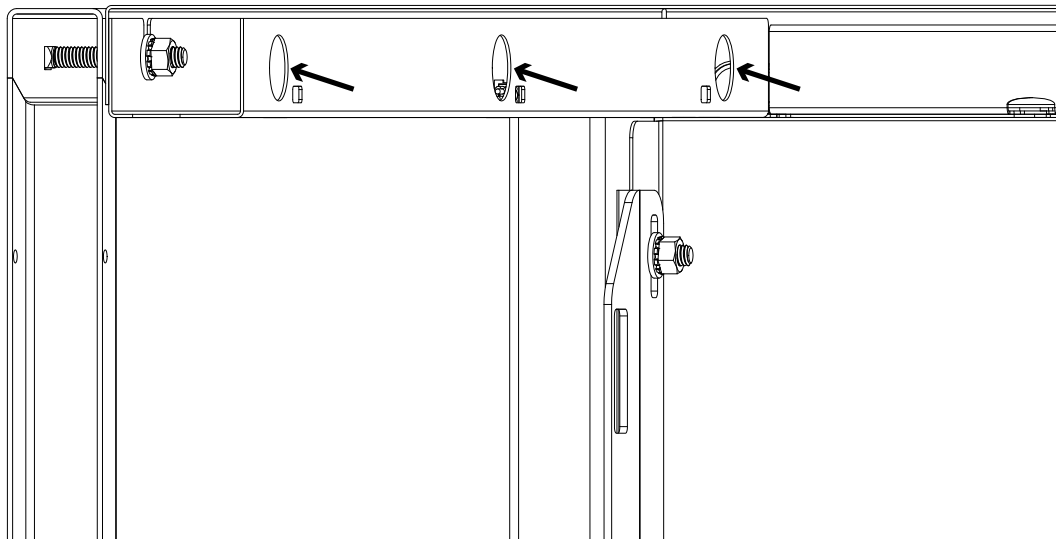

From inside the locker, the (3) 5/16" nuts in front, and (3) in back, can be tightened with a 1/2" extension socket through the holes in the cable guards. Note to be careful of the cables.

27

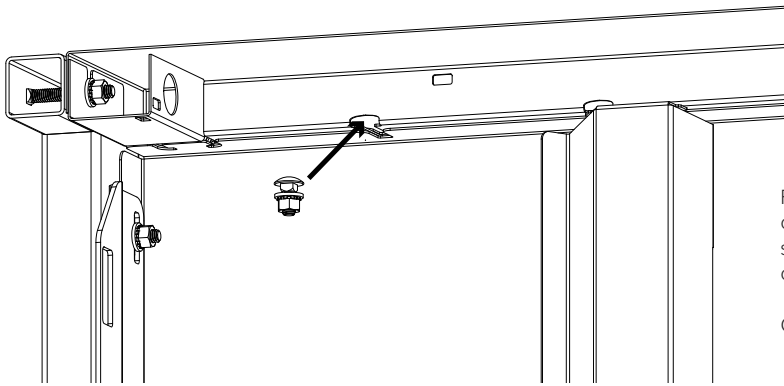

From inside the locker, place (3) assembled 5/16" x 3/4" carriage bolts, washers, and nuts in the slots on each side of the roof panel. Tighten all nuts. Note to be careful of the cables and wires.

Confirm all cables and wires are behind the guards.

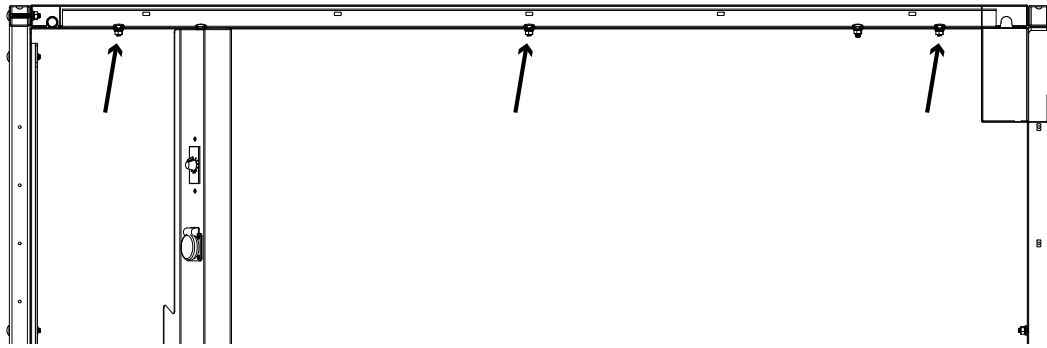

28

Confirm all locker assembly hardware is tight and that door locks operate properly.

5-LOCKER ASSEMBLY

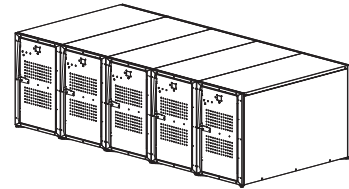
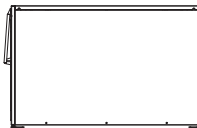
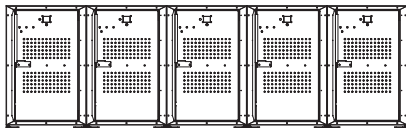

10-LOCKER ASSEMBLY

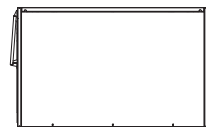
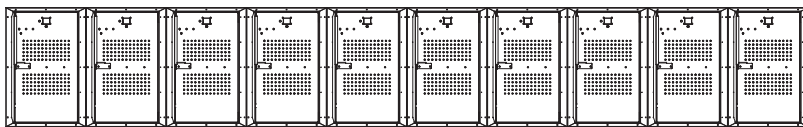

Smart Bike Locker Powered by Bikeep

SLA Comparison

	Standard Station SLA (Station SLA 1)	Premium Station SLA (Station SLA 2)
Monthly cost per set of connected lockers (max. 10)	\$84.00	\$139.00
<i>Internet connectivity¹</i>		
4G SIM card	✓	✓
Additional 4G SIM card for dual redundancy		✓
<i>Parking method</i>		
Bikeep app	✓	✓
Bikeep RFID contactless cards <i>(Must be registered via the Bikeep app prior to usage)</i>	✓	✓
Whitelist access		✓
Online management and monthly parking reports via Bikeep Console	✓	✓
<i>Station access</i>		
Public	✓	✓
Private (phone-based whitelist)		✓
Security camera integration ² (1 per set of connected lockers)		✓
<i>Reliability notifications</i>		
Bikeep internal monitoring	✓	✓
External Slack or custom webhook notifications		✓
<i>API</i>		
Real-time parking report API		✓
Whitelisted API		✓

¹ Internet connection signal (4G) must be validated at the station location by the client.

² Camera is sold separately.